

DELTA

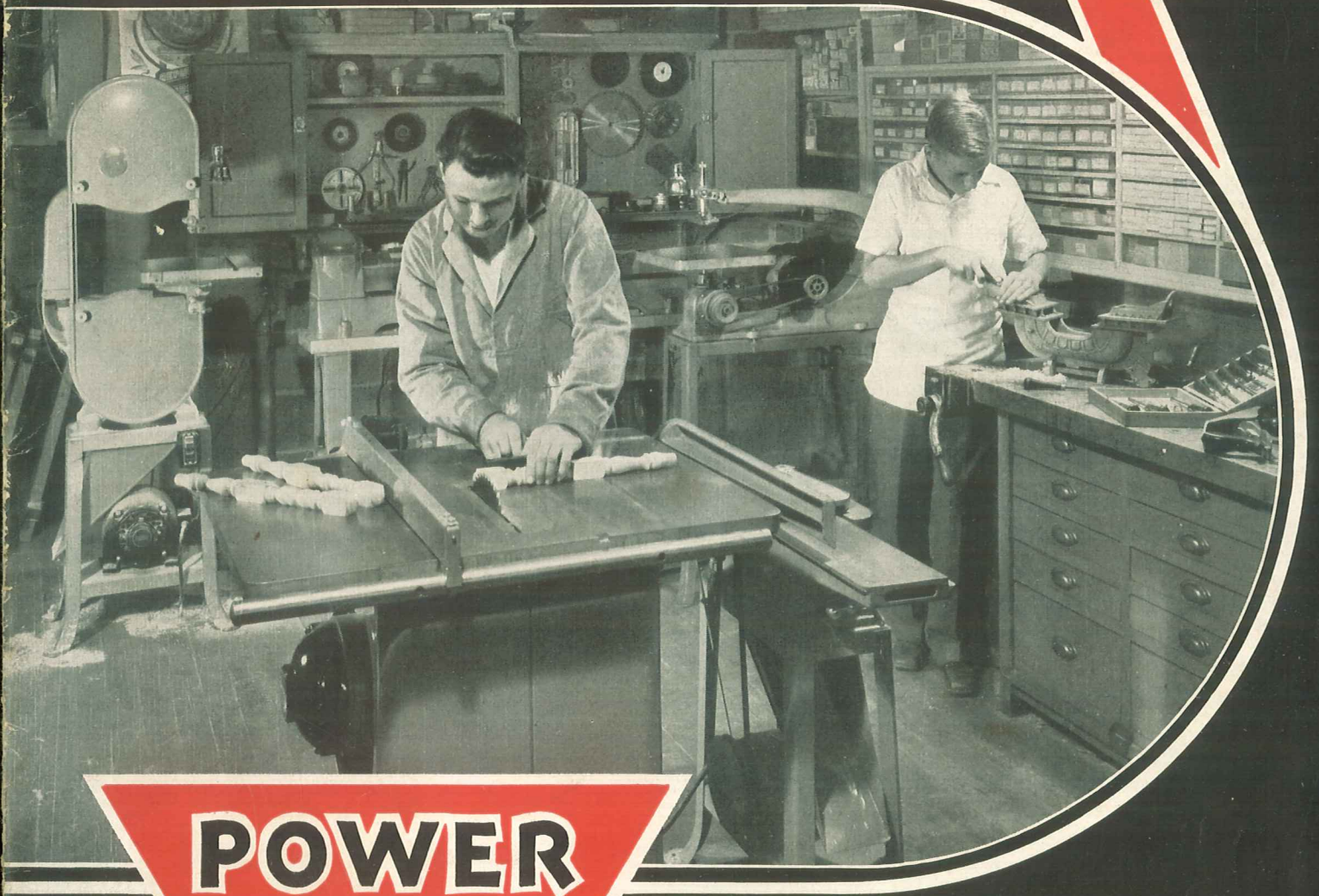

POWER TOOLS 1940

CATALOG
Q-1

CIRCULAR SAWS	Page 4
JOINTERS	11
COMBINATION UNITS	14
SHAPERS	15
PULLEYS, BELTS	20
SCROLL SAWS	21
SANDERS	25
MOTORS	28
BAND SAWS	31
GRINDERS	35
LATHES	36
DRILL PRESSES	40

How DELTA QUALITY POWER TOOLS ARE MANUFACTURED

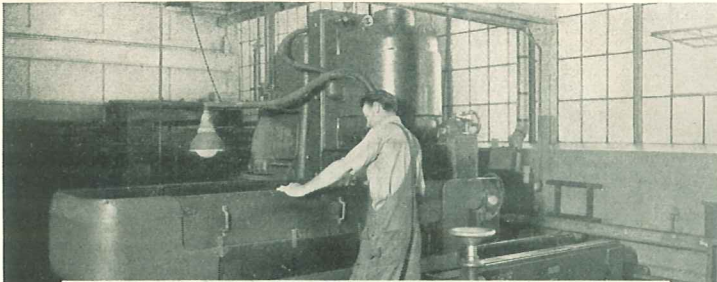

Powerful, accurate grinding machines insure absolute accuracy of all flat surfaces. All jointer tables are ground twice; once individually in accurate fixtures, then again after assembly with base, to assure precise alignment of finished machine.

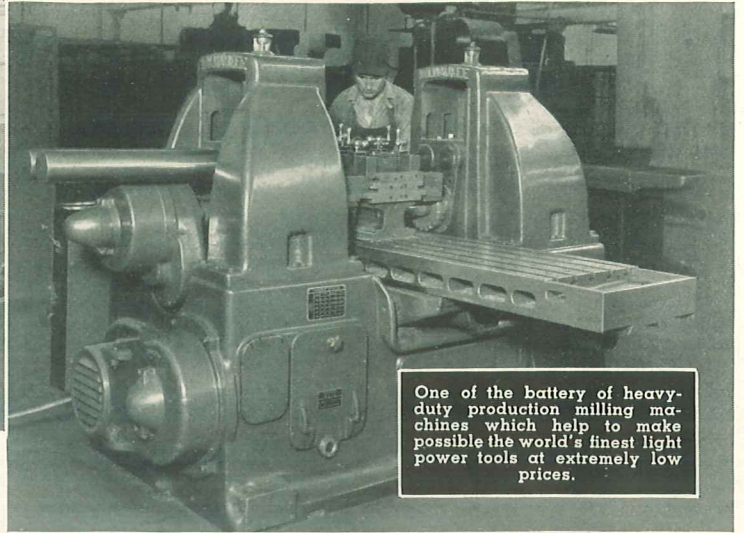

One of the battery of heavy-duty production milling machines which help to make possible the world's finest light power tools at extremely low prices.

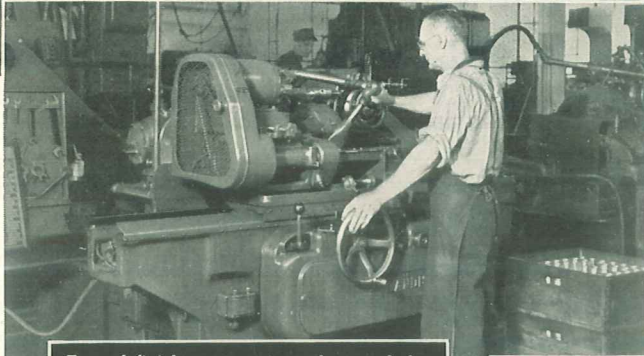

Turned finishes are not good enough for our light power tools. All spindles, arbors, collars, etc., are precision ground to finished sizes on the most modern type of grinding machines such as this.

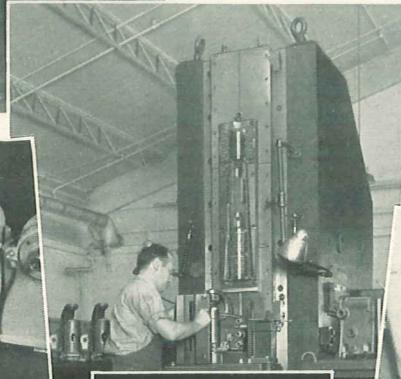

Modern high-production precision vertical broaching machine — one of many modern production units used in the manufacture of our power tools.



All ball-bearing seats and other bores where precision fits and accurate alignment are essential are "diamond-bored" on precision machines.



Pre-loading ball bearings to precision limits, to insure minimum deflection of bearings and maximum rigidity of shaft under load.

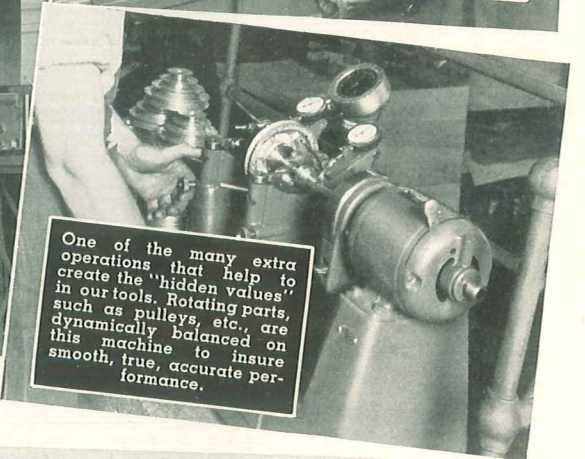

One of the many extra operations that help to create the "hidden values" in our tools. Rotating parts, such as pulleys, etc., are dynamically balanced on this machine to insure smooth, true, accurate performance.



Practically every worth-while improvement in light power tools made in recent years has been developed in this modern experimental shop, staffed with expert technicians and supervised by experienced engineers.

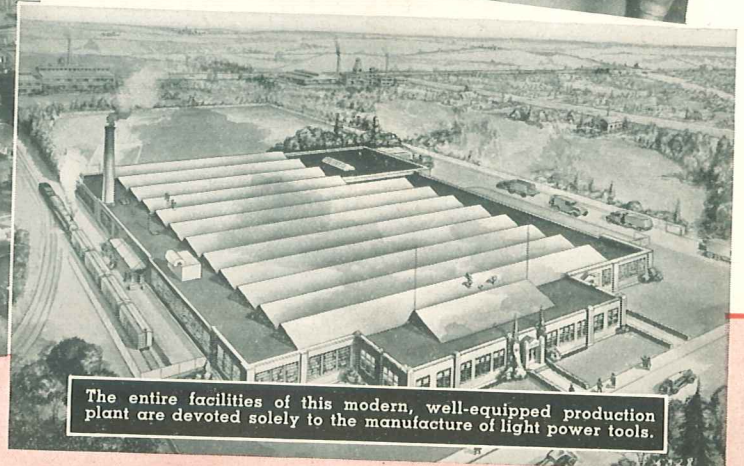

The entire facilities of this modern, well-equipped production plant are devoted solely to the manufacture of light power tools.

Why YOU OBTAIN THE MOST VALUE IN DELTA QUALITY TOOLS

Original Development

Delta was responsible for the original development of the light power tool into a machine of real utility for the small workshop, the school, the laboratory, the contractor and manufacturing plant.

Best Design and Construction

Delta tools have always been of high-grade design and construction. We have never made "cheap" tools, but from the first have concentrated on the manufacture of tools of the finest possible design—at the lowest possible price consistent with high quality. This policy has produced machines which, while they cost very little above "cheap" tools, are machines that are inexpensive to own.

Improvements in Power Tools

Practically every worth-while improvement in light power tools during the past twelve years has been developed, introduced and in many cases patented by Delta. This is a plain statement of fact that can easily be verified. Many of these developments have been adapted by others—but it is only in the Delta machines that can be found the features that make Delta design a real improvement. Because of the patents on our original improvements, many imitations lack the features that make Delta designs superior in performance and utility.

Superior Features

The details of Delta design, developed by knowledge, research and experience, can be shown to be superior, feature by feature, over those of any other make.

Concentration

Concentration on a single type of product has made possible the production of the finest light power tools it is possible to buy—and has made possible the growth of this company to the dominant position in the field. The Delta Manufacturing Company is the largest manufacturer making light power tools exclusively.

Knowledge and Experience

No other manufacturer making light power tools has so wide a knowledge or experience in the field. The value of this is shown by a simple fact: There have been fewer changes in the design of individual machines of our make, during the life of the tools, than in those of any other maker. This is because the tools are right to start with—and this is due to five factors: Widest knowledge and experience. Exceptionally careful design. Advanced engineering. Unusual production facilities. Thorough testing before introduction.

Remember—Other machines may look like Delta's, on casual inspection, but the hidden value of Delta design, as well as the more obvious advantages of the machines, make Delta machines, dollar for dollar, the best light power tools you can purchase for any purpose.

HIGH QUALITY AT LOW COST IS THE RESULT OF MODERN DESIGN AND CONSTRUCTION

Exactly the same combination of advanced engineering and modern production methods that produces a high-grade automobile is used to produce Delta power tools. A modern plant, modern precision machinery, quantity production—plus wide experience, knowledge and skill—these are the reasons why you buy so much in Delta machines at such low cost.

More than that, the details of Delta design and construction insure built-in values that may not be apparent on the surface. For example, many machines have ball bearings—but Delta machines are equipped with "sealed-for-life" ball bearings, which completely seal out dust and dirt, and completely eliminates lubrication problems. They are not merely shielded bearings. Further, all our ball bearings are mounted correctly and in

accordance with the best ball-bearing practice, not—as in many machines—in such a manner as to distort the bearings before they are even put into service. We also go to additional expense to "pre-load" our bearings, in order to insure minimum deflection and maximum rigidity under load.

Still further, we do not consider that plain boring and reaming of ball-bearing seats is good enough for Delta machines—so we "diamond-bore" all bearing seats to insure absolute accuracy and precise alignment. Diamond-boring is used also for many other operations where precision fits are required.

This is only one example out of hundreds, in which the details of Delta design and construction insure a definitely BETTER machine.

DELTA MACHINES ARE MANUFACTURED AND SOLD UNDER THE FOLLOWING PATENTS EITHER OWNED BY DELTA OR UNDER WHICH DELTA IS LICENSED. OTHER U. S. AND FOREIGN PATENTS ARE PENDING.

1,790,288	1,910,651	1,963,688	2,004,678	2,069,395	2,122,966	Des. 105,429	340,751—1934
1,830,813	1,925,477	1,964,651	2,007,887	2,073,430	2,168,282	Des. 105,621	346,174—1934
1,839,647	1,930,022	1,964,652	2,020,219	2,085,131	Des. 85,847	Des. 107,805	346,175—1934
1,877,705	1,938,548	1,967,791	2,020,222	2,085,235	Des. 89,818	Des. 109,628	351,531—1935
1,894,010	1,938,549	1,969,827	2,025,834	2,085,236	Des. 94,788		354,273—1935
1,896,924	1,941,417	1,975,562	2,032,233	2,099,321	Des. 98,280	Canadian Patents	354,274—1935
1,902,270	1,947,885	1,984,500	2,040,718	2,106,288	Des. 99,614	314,585—1931	365,682—1937
1,906,190	1,959,199	1,992,726	2,045,422	2,108,086	Des. 102,402	340,750—1934	370,828—1937

THE DELTA MANUFACTURING COMPANY, 600-634 E. VIENNA AVE., MILWAUKEE, WISCONSIN

EXPORT DEPARTMENT, 38 PEARL ST., NEW YORK, N. Y. (ADDRESS ALL CANADIAN COMMUNICATIONS TO MILWAUKEE OFFICE.)

All prices F. O. B. Factory, Milwaukee. Prices shown in this catalog supersede those quoted previous to October 1, 1939. All prices subject to change without notice. The right is reserved to make changes in design or equipment at any time, without incurring any obligation to install these on machines previously sold. Any sales tax imposed subsequent to the publication of this catalog will be additional to quoted prices.

ACCURACY—LONG LIFE—CONVENIENCE! . . . You Get More of These Values When You Buy One of Our Circular Saws!

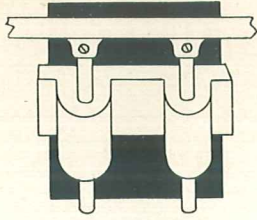

Gibbed, Machined Ways Adjustable for Wear

You will find many saws on the market today in which the guiding mechanism for the raising and lowering of the table or saw consists of round rods sliding through holes in the frame or bracket. This method, while cheap to manufacture, is one that we discarded years ago in favor of more rigid, more accurate and more substantial guiding means.

Brackets that are raised and lowered on our saws slide on large, accurately machined ways, dovetailed or grooved, and provided with gibs and adjusting screws just as in other high-grade machine tools. This not only provides a rigid, accurate, substantial mounting, but also permits adjustment for wear after long use if this ever becomes necessary.

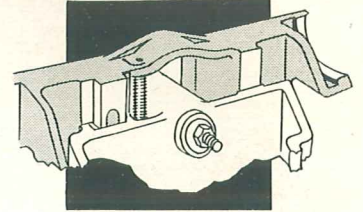

In our saws guides are completely machined, grooved or dovetailed and provided with adjustable gibs as in other high-grade machine tools.

In many saws the guides for the table or saw raising and lowering mechanism are merely rods sliding through holes. Not adjustable for wear.

Solid-Forged Steel Arbors

Most small and medium-size saw arbors consist of a steel shaft with one end shouldered and threaded, onto which the inner saw flange is pressed. Often this flange is not even machined after it is pressed on. On our 10" saws the entire

arbor, including the flange, is machined out of a solid alloy-steel forging. This not only prevents any possible loosening of the flange, but insures proper bearing mountings, true running saws and enormous strength.

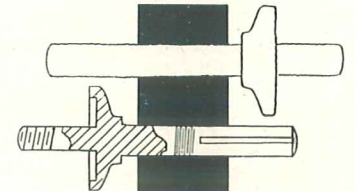

Saw arbors in our 10" saws are completely machined out of solid-steel forgings—no loose flanges. They are mounted in sealed-for life ball bearings, which never require lubrication.



In many saws the saw-armor flange is merely pressed onto the shaft and in some cases is not machined to insure true-running.

In addition, many small saw shafts are carried in bronze bearings, requiring constant lubrication. Where ball bearings are used, they are often poorly mounted or of shielded type which require lubrication.

Ball or Timken Bearings—Properly Mounted

The solid alloy-steel arbors of our saws are carried either in genuine Timken tapered-roller bearings or in "Sealed-for-Life" New Departure ball bearings (not merely shielded bearings). There are no lubrication problems with these ball bearings, and they re-

quire no attention whatever during their entire life. All our bearings are mounted in accordance with the best ball-bearing practice—not merely mounted in the cheapest possible way, which sometimes injures the accuracy of the bearings even before they are used.

Full-Length Fences—Locked Front and Rear

Some circular saws have rip fences which barely extend beyond the rear teeth of the saw blade, and which can be locked only at the front. In the opinion of many expert woodworkers such short fences are very dangerous, due to the release of pressure behind the blade, which

tends to throw the work or the hand into the rear saw teeth. Our saw fences extend completely across the table from front to rear, so that this danger is completely eliminated. They are locked front and rear, so that they are practically solid with the table.

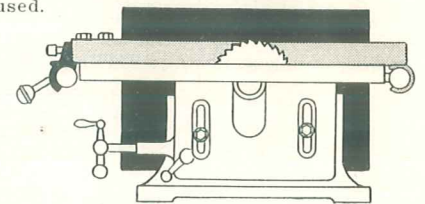

Our rip fences run completely across the table from front to rear. Not only that, but they can be locked so firmly to the front and rear guide bars that they become as rigid as the table itself.

And Used on BOTH Sides of the Blade

Our fences have a further advantage of great importance. They can be used on both sides of the blade—which cannot be done in many saws. This fea-

ture is essential to the use of double-faced moulding cutters and cope heads in the circular saw, and is of great advantage in a wide variety of other work

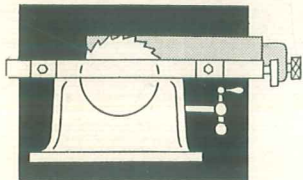

Many saws have rip fences which barely reach beyond the rear of the saw. Many woodworking experts regard this as a very dangerous type of fence. Most fences, also, cannot be used on both sides of blade.

Guards that Really Protect the User

Most small circular saw guards are flimsy in design and construction and are actually more of a nuisance than a real safety feature. Notice that our No. 863 and No. 1185 guards are NOT mounted on a splitter, where they must be removed completely for most cross-cutting and for all dado and moulding work. They are mounted in a solid, substantial manner so that they cannot chatter or vibrate into the saw, yet they are instantly moved out of the way for dado and similar work **without removing them from the machine**. Notice also that they may be used either with the splitter or without—and that the splitter may be used alone. We believe that this is the finest guard ever designed for saws of this type.

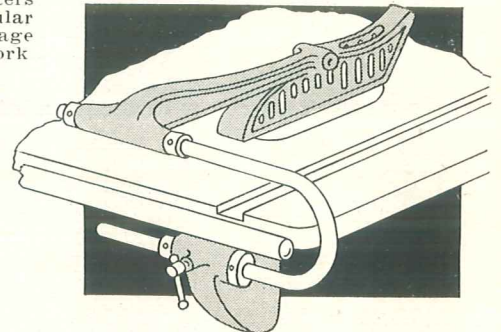

Our very substantial guard is carried on a strong, heavy support rod and a heavy, rigid bracket.

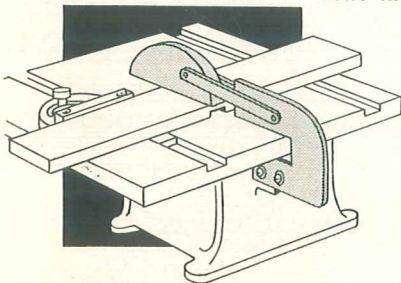

Many saws have guards similar to the type shown above. This guard must be removed completely every time a dado cut is made or a moulding cutter used. The basket guard also cannot be used without the splitter. The mounting is often a weak and flimsy one.

And Many Other Features that Mean

More Satisfaction for You!

Consider the "Auto-Set" miter gage, widely imitated by others, but the only miter gage offering you individually adjustable stops, to assure you of absolute accuracy in setting. And the adjusting screws in the table insert, which enable you to set the insert exactly level with the table. Consider the "hidden values"—the extra machining for accuracy (like the machining of the table-insert opening, instead of leaving this just rough)—the diamond-boring of the ball-bearing seats for absolute accuracy.

Consider the extra convenience of the controls—like our adjustable clamp handles and our graceful, large-size operating cranks. Consider the advantage of being able to mount our tilting-table saws on a neat, compact stand together with a jointer and to be able to run them both from below with one motor.

Contrast the details of design shown above and on the following pages with those you will find in any similar saw anywhere. We believe you will then realize the **extra value** built into these saws!

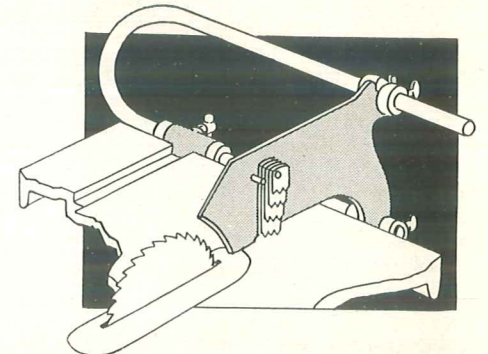

The splitter, with its kick-back fingers can be used alone. The guard basket can also be used without the splitter—or basket guard and splitter can be used together to suit any type of work. Instantly out of the way, and instantly back in place.

BEST SAW MADE: This 10-inch Tilting Table Saw Meets The Most Exacting Demands Of The Craftsman

Cuts Stock
3 1/4 in. Thick

Rips to Center
of 50 in. Panel

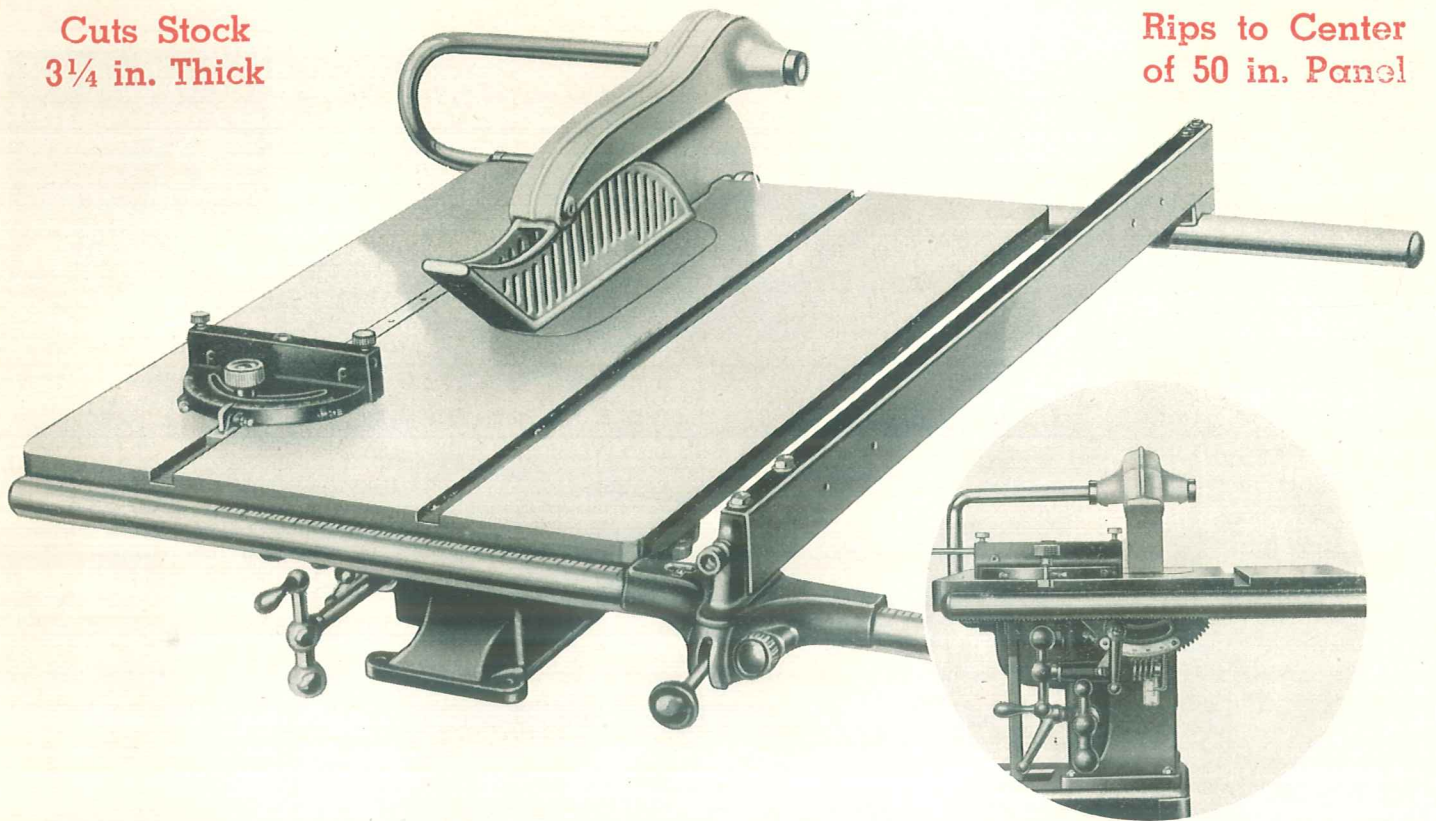

This fine saw is a real man-size machine, with its husky 20 by 27-inch table, its sturdy tubular rip-fence guide bars—and all the features that have won such a reputation for the 8-inch saw—PLUS greater capacity and added conveniences.

Designed for craftsmen who need and demand the best there is in workshop equipment, this 10-inch circular saw was built with just one thought in mind: To produce a saw that would offer more accuracy, more capacity, more conveniences, more built-in VALUE than any similar saw on the market, regardless of price!

That this object has been achieved will be recognized by every mechanic and craftsman as soon as the No. 1160 circular saw is examined with care. From the heavy-walled tubes that form the

rip-fence guide bars—a full 1 3/8 inch in diameter, and stronger to resist bending and torsional stresses than any other section of equal weight—to the hidden but important solid-forged alloy-steel arbor with its self-sealed New Departure ball bearings, every detail has been worked out to give the utmost satisfaction to the user.

The "Micro-Set" rip fence is carried on a heavy casting at the front, locked to the front guide bar by a neat cam lever with a Bakelite ball handle. The rear lock is operated from the front also, so that the hands never need be near the blade when locking the fence. And it is impossible for this fence to move or spring. The miter gage is the famous "Auto-Set" miter gage, with INDIVIDUAL adjustments for 45 and 90-degree settings.

Crosscuts Stock 12 Inches Wide

From the saw blade to the front edge of the table, the table surface measures 12 1/2" wide, so that stock a full 12" wide and 3 3/4" thick can be cut easily, with full bearing on the table surface for both the work and the

miter gage. And, in providing adequate surface in front of the blade, *this has not been done at the expense of the rear surface, for there are 5" of table behind the blade to support the work as it leaves the saw.*

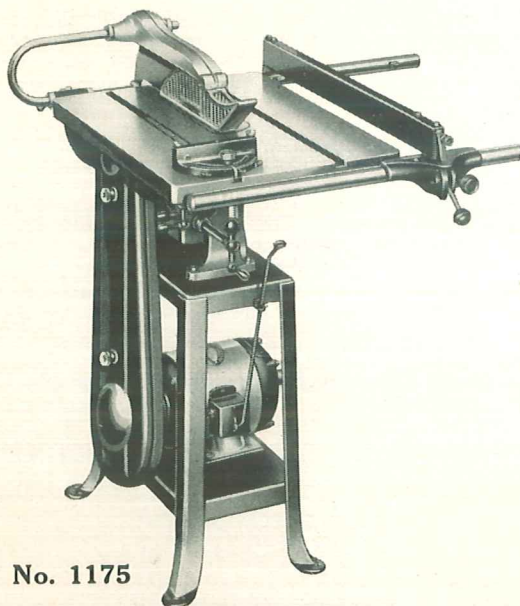

No. 1175

No. 1160	10" Ball-bearing Circular Saw, with "Auto-Set" Miter Gage, "Micro-Set" Rip Gage, graduated front rip-gage guide bar and plain rear guide bar. Without motor, belt, motor pulley or saw guard.....	\$55.85
	Shipping Weight 190 lbs. Code Word TENSE.	
No. 560	V-belt (56" inside circumference).....	1.00
	Shipping Weight 1 lb. Code Word EICVB.	
No. 5500	5" V-pulley for motor, 3/4" bore.....	.75
	Shipping Weight 1 1/2 lbs. Code Word PULOH.	
No. 891	Steel stand (Top 7 7/8"x15 7/8"; 24" high).....	6.85
	Shipping Weight 30 lbs. Code Word LABST.	
No. 530	V-belt (53 5/8" inside circumference).....	1.00
	Shipping Weight 1 lb. Code Word BELTD.	
	(Note: No. 530 belt must be used with 10" saw on No. 891 stand. No. 560 belt is used with 10" saw on No. 1168 stand.)	
No. 1173	Belt Guard for No. 1160 saw on No. 891 stand.....	7.85
	Shipping Weight 36 lbs. Code Word TENBG.	
No. 1175	10" Circular-Saw Unit, consisting of No. 1160 Circular Saw, No. 530 V-belt, No. 5500 V-pulley and No. 891 Steel Stand. Without motor, switch rod or saw guard. Shipping Weight 250 lbs. Code Word TENSQ.	\$64.45

No. 9000 or 8050 (old No. 820 and 1120) motors recommended for this machine for ordinary use. For heavy duty specify No. 9100 (old No. 924) No. 9200 (old No. 1094) No. 9400 (old No. 922) or No. 9502 (old No. 1512) 3/4-H.P. and 1-H.P. motors. See pages 28-30.

FOR 10 INCH TILTING ARBOR SAW, SEE BACK COVER

10-INCH SAW FEATURES: Many Design Advantages Found Only In This Remarkable Tilting Table Saw

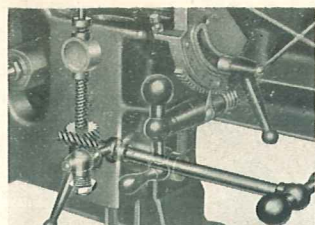

Raising Mechanism

Table raising and lowering is done by means of a helical gear on a shaft operated by a comfortable, free-handle ball crank. The gear meshes with another running on the ball-bearing raising screw, elevating or lowering the table with ease and speed. The pitch of the screw is chosen to provide a fast movement, while at the same time it is fine enough for close adjustment of depth.

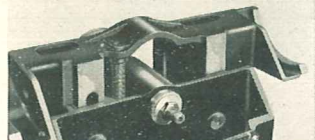

Machined Ways

There are cheaper ways of fitting the table to the base than that employed on this saw, but none of these was thought satisfactory enough for a good machine...so the table is elevated and lowered on machined ways.

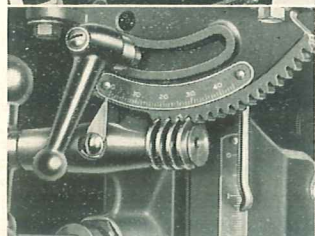

Worm-Gear Tilting

The table is positively tilted by means of a worm and rack, the worm operated by means of another comfortable ball crank. Accurate and convenient etched scales are provided for height and tilting adjustments, each provided with an adjustable pointer for accuracy. The adjustable height pointer is especially useful for dado and similar work.

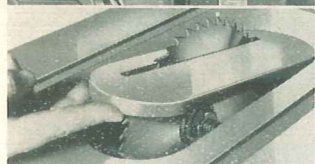

Quick-Acting Inserts

Table inserts are fitted in machined openings in the table—not rough cast holes. They are instantly snapped in or out with a touch of the finger—no screws to loosen. And (U. S. Pat. No. 2,020,222) they are provided with adjusting screws so they may be made to lie perfectly flush.

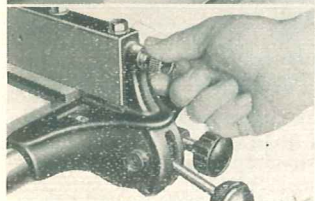

Rear Rip-Fence Lock

The patented construction not only provides a rigid rip fence, locked to the guide bars at front and rear, but in this saw all the fence controls are at the front—no reaching over the saw blade to loosen or tighten the rear lock. More convenience and safety!

CROSS CUTS 12" WIDE

RIPS 3 1/4" DEEP

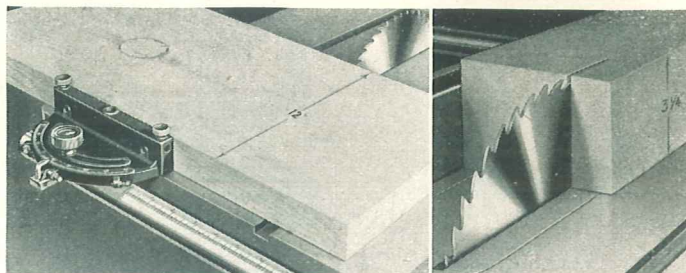

Rips to Center of 50" Panel with Standard Guide Bars

Most saw tables—even in 10" size—are too small. So in designing this saw, we produced a 20 by 27-inch table surface for the standard machine. In front of the blade—the "Zone of Service" where surface is most needed, there is 12 1/2" of table space, so that a 12" board to be crosscut is supported in its whole width by the table, and the miter gage also has ample bearing on the table. And there is ample surface—5"—in back of the blade also!

The table itself is an exceptionally heavy ribbed casting.

The rip-fence guide bars are a typical improvement. They are heavy walled tubes, 1 3/8" diameter, chosen because tubes, as every mechanic knows, resist bending and torsional stresses better than any bar section of equal weight. They therefore hold the fence rigid and in perfect alignment under all circumstances. And, with the STANDARD guide bars, the saw will rip to the center of a 50" panel without the necessity of changing guide bars.

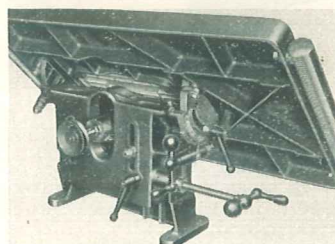
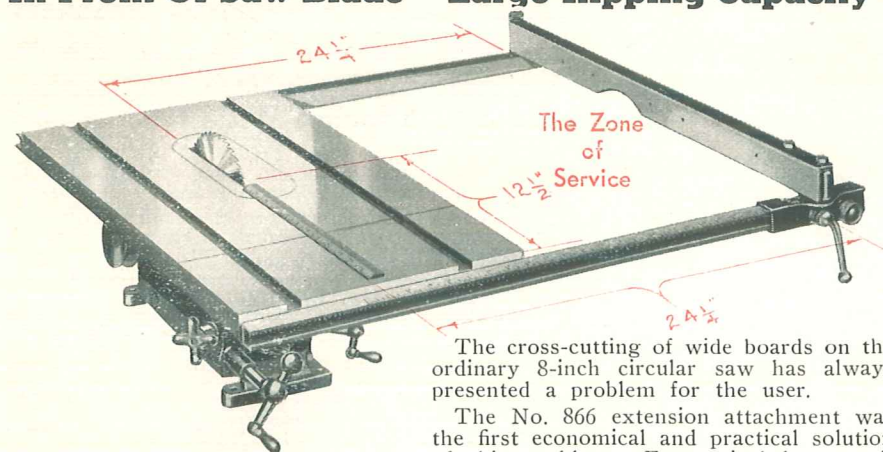

Photo at left shows the table tilted to 45 deg. Notice the scientifically ribbed and very heavy table, swinging on massive trunnions. This is a more expensive construction, but is the only one that permits the safety of a very narrow opening around the saw blade, since the table tilts in the plane of the table surface.

8-IN. SAW, INCREASED CAPACITY Extra Space Right Where It Is Needed In Front Of Saw Blade — Large Ripping Capacity — Attached Or Removed In Jiffy



The cross-cutting of wide boards on the ordinary 8-inch circular saw has always presented a problem for the user.

The No. 866 extension attachment was the first economical and practical solution of this problem. Economical because it enabled the man who needed extra capacity on this table to obtain it economically, without penalizing the user who used his saw only for small work; practical because the table extension provided the room in front of the saw, where it is needed. Side wings added to increase the width of the table are of no value for this purpose, as the problem of adequate room for wide boards still remains. The real utility of this extension becomes even more apparent when a wide board must be mitered accurately—a job that cannot be done at all on many saws. As the photo above shows,

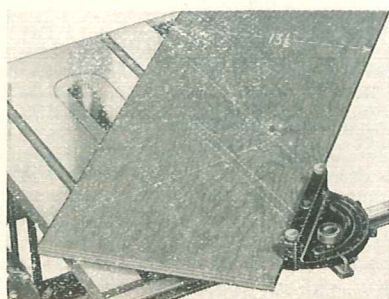

the mitering of a panel 13 or 14 inches wide would be practically impossible without the extension, because neither work nor gage would have any support, and accurate work would thus be out of the question.

Next to cross-cutting, the next most important problem for the 8" saw user is that of ripping large panels and similar work. He usually either must do this "by eye," or else build some kind of extension table—both usually unsatisfactory.

A longer rip-gage body is used with extension table.

With the extension bars in place panels as wide as four feet can be ripped down the center with accuracy and speed, and the work is accurately guided and adequately supported during the operation.

No. 866 Extension Attachment, with front-table extension, 32" rip-gage guide bars, \$8.85 long rip fence bar only, nuts and bolts..... Shipping Weight 22 lbs. Code Word NECTX.

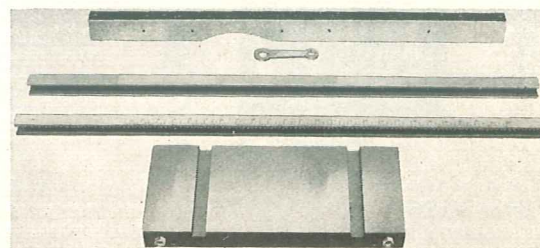

PATENTED CONSTRUCTION of This 8-Inch Timken Bearing Circular Saw Gives You Many Unique Features and Advantages Not Found In Other Units

Cuts 2 1/4" Thick

Overall Dimensions:
23" Front to Back:
18 1/4" Wide 11" High



No. 860 Circular Saw

A cross-section through the arbor housing, showing how the heart of the saw is built for real heavy duty and for maximum service.

No. 878 Unit

Read All of These Points: They Are Important to You

1. The great capacity in front of the saw blade — where you need it most for cross-cutting wide boards—together with the tremendous ripping capacity offered by the rip-gage extension, are fully covered by our patents. Only in this circular saw can you obtain these patented advantages of construction and design—concrete evidence of its superiority. (Pat. No. 1,933,549).
2. The rip-gage extension, which gives the user all the advantages of a four-foot table, without the weight and expense, is fully protected by the above patents. You cannot obtain these advantages in any other manner. (Pat. No. 1,896,924 and No. 1,938,548).
3. An original design, the wonderful "Auto-Set" miter gage is also fully patented. Both the massive design and the automatic stops which make this the most convenient gage ever offered on any circular saw, are protected by patent. (Pat. No. 1,902,270). (Des. Pat. No. 89,818). (Can. Pat. No. 340,750).

4. If you insist on absolute accuracy in your work you can obtain it only with a clamp attachment for the miter gage, which absolutely prevents any creep of the work away from the blade. The clamp attachment is fully protected by patent. (U. S. Pat. No. 1,894,010). (Can. Pat. No. 340,752).
5. The patented rip-gage has a number of important advantages, amongst which are its self-alignment, its graduations and adjustable pointer, its rear clamp and its micrometer adjustment, disengaged at will, with fine teeth to permit a real close adjustment for accurate work. (U. S. Pat. No. 1,963,688).
6. The patented table trunnion construction has a number of superior features; it permits the use of a very narrow table slot for the blade, and avoids the necessity of removing the table insert when the table is tilted. When the table is raised and tilted the rip-gage is not thrown out of alignment with the saw blades. (U. S. Pat. No. 1,697,669 and 1,910,651).

No. 860	8-inch Circular Saw, with 8" blade, "Auto-Set" Miter Gage, "Micro" Adjustment Rip Gage and Arbor Pulley, complete as shown in photo above.....	\$32.85
	Shipping Weight 91 lbs. Code Word NECSA.	
No. 5500	5" Motor Pulley, drives saw at correct speed. Made with 1/2", 5/8" or 3/4" bore. Specify bore wanted. 1/2" bore furnished unless otherwise specified.....	.75
	Shipping Weight 1 1/2 lbs. Code Word PULOH.	
No. 560	V-Belt, 22 7/8" center to center.....	1.00
	Shipping Weight 1 lb. Code Word EICVB.	
No. 862	Circular Saw, complete with No. 866 Extension Attachment but without standard-rip gauge bar or standard guide bars.	39.95
	Shipping Weight 110 lbs. Code Word NECWX.	
	No. 9000 or 8050 Motor recommended for this machine.	
	See pages 28-30 for Motor and Switch-rod prices.	

No. 878 Circular-Saw Unit	
The No. 860 Circular Saw mounted on its individual stand is a very popular unit. It is especially convenient in the profession and school shop, as it is completely portable.	
Our No. 9000 1/2 H.P. Repulsion-Induction Motor is recommended for use with this unit. Use No. 1330 switch rod.	
No. 878—8" Timken-Bearing Circular Saw Unit Includes:	
No. 860	Circular Saw \$32.85
No. 5500	V-Pulley, 3/4" bore75
No. 560	V-Belt, 22 7/8" center to center..... 1.00
No. 329	Steel Stand (without chute), with bolts & directions. (Stand 29" high, Top 7"x12 1/2") 5.75
	Total \$40.35
	Shipping Weight 122 lbs. Code Word NECUN.

ATTACHMENTS Make Saw Operations Safe and Accurate

TENONS MADE FAST, EASY and ACCURATE

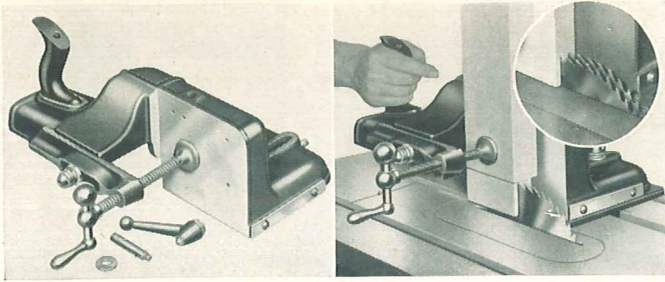

Every possibility of risk in cutting tenons is done away with when using our new Tenoning Attachment. This consists of a massive casting, which may be fastened to the base plate of the No. 1186 Sliding Jig, and this, in turn, is guided by the miter-gage grooves in the saw table. The stock to be tenoned is clamped by means of a quick adjustment against an accurately machined surface so that it is exactly vertical and parallel to the saw blade—no chance for twisted tenons—and the whole attachment is fed to the blade by means of a convenient handle at the rear. The work is fed to the saw with one hand—far removed from the revolving blade. There is no need for the hands to be anywhere near the saw blade at any time, and thus every possibility of accident is removed from the operation.

The attachment will take stock up to 2 3/4" thick, any width within the capacity of the saw, and tenons to 2" long on an 8" saw. With the use of No. 1171 spacing collars and an extra saw blade, 1/4" or 3/8" tenons can be cut at one pass.

- No. 1170** Tenoner for use with No. 1186 Sliding Jig. Consists of all parts as shown above, without base plate..... **\$7.75**
Shipping Weight 20 lbs. Code Word TENJG.
- No. 1172** Tenoner complete with base plate **11.25**
Shipping Weight 32 lbs. Code Word TENBP.
- No. 1171** Spacing collar set (one 1/4" and one 3/8" collar) **.75**
Shipping Weight 10 oz. Code Word TENCO.

CLAMP INSURES ACCURACY; NO WASTE

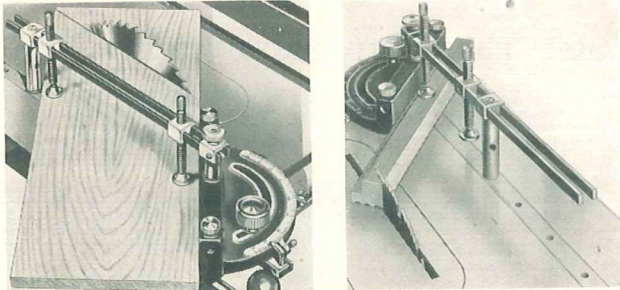

The clamp attachment assures perfect safety in cross cutting and mitering, because the gage, carrying the clamped work, can be slid into the cut with one hand, back of the miter gage. The hand need never be in front of the miter gage or near the blade—and it is only on this gage with clamp attachment that this is true. With every other gage it is necessary to have one hand in front of the gage to hold the work.

With this clamp there is no spoilage due to slippage—once clamped you know the cut will be true and accurate. For heavy, large boards it is of tremendous value—use it once and you never will be without it again.

- No. 865** Miter Gage Clamp Attachment, consisting of Clamp Bars, two Sliding Clamp Screws, Front and Rear Posts, to fit No. 864 Miter Gage only..... **\$1.95**
Ship. Wt. 2 1/4 lbs. Code Word NECLA.
- No. 873** Extra Clamp Screw and Block for Clamp Attachment..... **.45**
Ship. Wt. 4 ozs. Code Word NECCS.

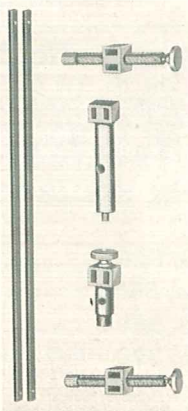

MITER GAGE ADDS CONVENIENCE

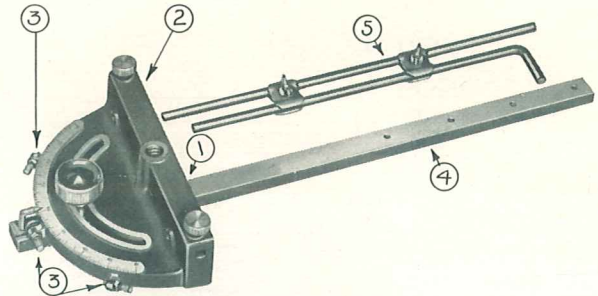

The first automatically indexed miter gage ever offered, and the only one with individually adjustable index stops, the "Auto-Set" Miter Gage offers the following unique advantages:

1. Unique tapered pivot insures close fit for entire life of gage, thus preserving accuracy.
2. Massive body, heavier than many gages on production machines, gives full support and will not spring. (Des. Pat. No. 89,818).
3. Individual automatic stops (U. S. Patent No. 1,902,270; Canadian Patent No. 340,750) make precision job of cross and miter-cutting. Only miter gages made under our patents have individual index adjustment, a necessity for absolute accuracy.
4. Heavy 3/8" by 3/4" bar, very rigid and strong, 17" long.
5. Full 1/8" diameter stop rods, with two heavy clamps, not flimsy wires that are useless for accurate repetition work.

- No. 864** "Auto-Set" Miter Gage, with 3/8" x 3/4" bar, two with 3/8" x 3/4" stop rods with clamps. Fits any table **\$3.50**
Shipping Weight 4 1/2 lbs. Code Word NECMI.

MORTISER INCREASES OPERATIONS

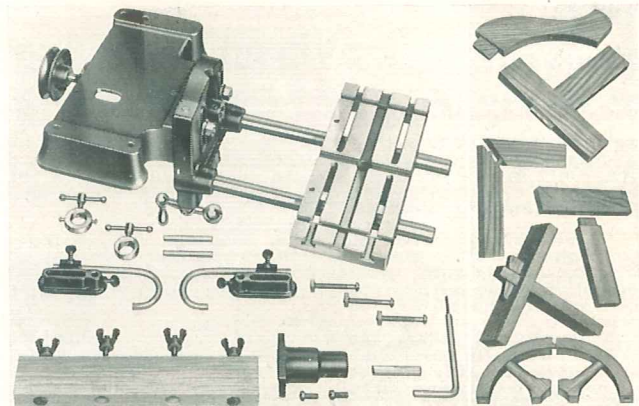

The addition of the No. 458 Mortiser and Router to your No. 860 Circular Saw enables you to perform many difficult operations with ease. Boring, routing, mortising, grooving, counter-boring, inlaying, sanding and many other operations are performed on this attachment with accuracy and speed.

It may be mounted under the base of the No. 860 saw, or it may be used alone on stand or bench—there is no end to the convenient ways in which it can be used. **Not adapted to the No. 1160 10" saw.**

- No. 458** Mortiser and Router only, includes everything shown in the photo..... **\$26.25**
Shipping Weight 42 lbs. Code Word MORBO.
- No. 453** V-Belt for above; Center to center distance, 17 3/8" **\$.90**
Shipping Weight 1 lb. Code Word MOREBL.
- No. 583** V-Belt for circular saw, when Mortiser is used with Unit No. 368 (No. 560 belt is then too short). Center to center distance 24" **\$1.10**
Shipping Weight 1 lb. Code Word FORBL.
- No. 461** Foot-Power Feed for No. 458 Mortiser fits our Steel Stands **\$4.25**
Shipping Weight 8 lbs. Code Word MORFE.

GUARDS Provide The Maximum Protection To The Saw User

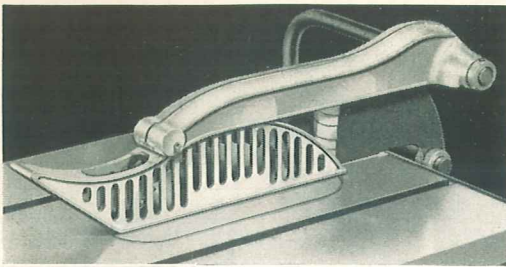

These guards may be swung completely back and out of the way in a second's time, and as quickly swung back when needed. They need never be removed for any reason.

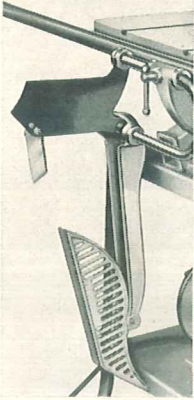

These Circular-Saw Guards (U. S. Pat. No. 2,007,877) have been praised by all authorities as the only guards that really protect the saw user, while at the same time they do not interfere with his work. No other guards that we know of offer all the features of these, which meet the very exacting requirements of many Industrial Commissions.

The new "Anti-Kickback" attachment (right) an integral part of the splitter for the 10" saw, prevents the work being kicked back against the operator if the kerf pinches on the saw blade. It is invaluable when sawing poorly seasoned or warped wood. The kickback fingers take all work from the thinnest strips up to the full capacity of the blade, and adjust themselves to the work without any attention on the part of the operator.

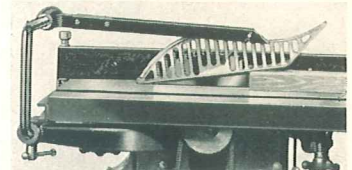

Work entering guard on No. 860 8" saw. This guard while slightly different in construction details, has all the features of the larger guard.

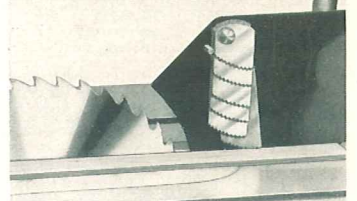

Kick Back and Splitter

The splitter shown is the only practical type. It comes in three thicknesses to suit saws of different sets, it may be attached or detached in a moment, may be used either with or without the basket, and it floats to accommodate itself to the kerf.

No. 863 Swing Guard for No. 860 Circular Saw, complete with bracket, support rod, pivot arms, guard basket, collars and screws. Ship. Wt. 9 lbs. Code Word NECGA... **\$4.85**

No. 877 Splitter Attachment for No. 860 saw, consisting of 3 splitters, 2 collars for support rod, and kick-back fingers. Shipping Weight 3 lbs. Code Word NECSC..... **\$2.75**

No. 1165 Swing Guard for No. 1160 Circular Saw, with bracket, support arm, pivot bracket, basket, collars and screws. Shipping Wt. 19 lbs. Code Word TENSK.... **\$11.50**

No. 1166 Splitter Attachment for No. 1160 Circular Saw, consisting of three splitters, anti-kickback and collars for support arm. Shipping Weight 5 lbs. Code Word TENSL **\$3.75**

HOLLOW GROUND SAW BLADES

Ideal for fine and accurate work. The teeth have no set, and the work comes from the saw ready to put together, unless of such fine character that it requires jointing. This blade is intended for fine work only; it is not suitable for rough cutting. Properly used and cared for it will do the highest grade of work.



No. 326 8" Hollow-Ground Blade for No. 860 Circular Saw, $\frac{5}{8}$ " arbor hole..... **\$5.50**
Shipping Weight $1\frac{1}{2}$ lbs. Code Word EICSP.

No. 1016 10" Hollow-Ground Blade, for No. 1160 or 1450 Saw, $\frac{5}{8}$ " hole..... **\$6.50**
Shipping Weight 2 lbs. Code Word TENSR.

COMBINATION SAW BLADES

Combination Saw Blade rips and cross-cuts equally well. Serves a very useful purpose for general work. Teeth have proper set. Made of high-grade steel, properly tempered.

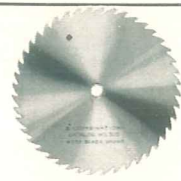

No. 325 8" Combination Rip and Cross-cut Blade, for No. 860 Circular Saw, $\frac{5}{8}$ " arbor hole..... **\$3.00**
Shipping Weight $1\frac{1}{2}$ lbs. Code Word EICBL.

No. 1015 10" Combination Rip and Cross-Cut Blade for No. 1160 for 1450 Circular Saw, $\frac{5}{8}$ " arbor hole. Shipping Weight 2 lbs. Code Word TENSPL..... **\$3.75**

No. 1017 10" Rip, for 1160 saw. TENS. 2 lbs..... **3.75**
No. 1018 10" Crosscut, for 1160 saw. TENS. 2 lbs..... **3.75**
No. 334 8" Rip, for 860 saw. EICBR. $1\frac{1}{2}$ lbs..... **3.00**
No. 335 8" Crosscut, for 860 saw. EICBC. $1\frac{1}{2}$ lbs..... **3.00**
Above blades have $\frac{5}{8}$ " arbor hole.

CUTTING WHEELS for METAL, Etc.

Abrasive Cutting Wheels will cut freely and fast all of the materials listed below, and many other materials. All are $\frac{3}{8}$ " thick, 8" diameter, and have $\frac{5}{8}$ " arbor hole only. Bonded with genuine synthetic resin; should not be confounded with shellac-bond wheels.



No. 223 8" Cutting Wheel, $\frac{3}{8}$ " thick, $\frac{5}{8}$ " hole, for cutting vitrified brick, cast iron, sand cores, slate and plain or glazed tile. Ship. Wt. $1\frac{1}{2}$ lbs. Code BAKEC... **\$1.75**

No. 225 8" Cutting Wheel, $\frac{3}{8}$ " thick, $\frac{5}{8}$ " hole, for cutting monel metal, steel tubing, hardened steel, stellite, stainless steel, aluminum tubes, etc. Sh. Wt. $1\frac{1}{2}$ lbs. Code BAKED... **\$1.75**

No. 227 8" Cutting Wheel, $\frac{3}{8}$ " thick, $\frac{5}{8}$ " hole, for cutting porcelain, hard rubber, brass tubing, copper, brass and bronze. Ship. Wt. $1\frac{1}{2}$ lbs. Code Word BAKEF..... **\$1.75**

No. 228 8" Cutting Wheel, $\frac{3}{8}$ " thick, $\frac{5}{8}$ " hole, for cutting soft steel and wrought iron..... **\$1.75**
Shipping Weight $1\frac{1}{2}$ lbs. Code Word BAKEH.

HOLD DOWNS KEEP FINGERS FROM BLADE



This attachment consists of a clamp which fits either side of the saw table, and which carries adjustable springs to bear on the work. One spring is adjusted to press the work to the fence and the other to press it down to the table. With this attachment the fingers need never come near the revolving blade at all.

No. 871 Hold-Down for No. 860 and 1160 Saws, with clamp, brackets and springs..... **\$2.60**
Ship. Wt. $4\frac{1}{2}$ lbs. Code Word NECHO.

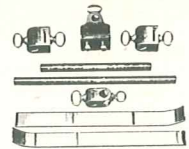

Note: To adapt No. 983 shaper hold-down to fit circular saw, order the following parts:

NCS-315-S Clamp Bracket, each..... **.75**
DP-331 Short rod ($\frac{1}{2}$ "x $6\frac{3}{8}$ "") each..... **.20**
NCS-316 Long Rod ($\frac{1}{2}$ "x $11\frac{1}{8}$ "") each.... **.25**

GUARDS FOR ABRASIVE CUTTING WHEELS

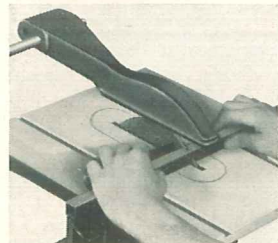

The guard is made of heavy cast iron, completely closed so that no particles can be thrown out.

No. 230 Abrasive Wheel Guard, with bracket and arm, **\$4.25**
to fit No. 860 Circular Saw.
Ship. Wt. 12 lbs. Code Word BAKEI.

No. 231 Top Guard casting only. Used wherever saw is already fitted with circular-saw guard. Fits only No. 318 or No. 860 Circular Saw..... **\$2.50**
Ship. Wt. 7 lbs. Code Word GURDA.

No. 1470 Bent Arm and Bracket to fit No. 1155 Abrasive wheel Guard to No. 1450 Saw. Sh. Wt. 14 lbs. Code TILGA... **\$6.50**

No. 1156 Bent Arm and Bracket to fit No. 1155 Abrasive Wheel Guard to fit No. 1160 Saw. Shipping Weight 15 lbs. Code Word TENG... **\$5.85**

No. 1155 Abrasive Wheel Guard, cast, for No. 1160 or 1450 Saw, less arm and bracket. Sh. Wt. 11 lbs. Code TENGA. **\$4.50**

DADO HEAD CUTS CLEAN, SHARP GROOVES



For cutting of grooves varying in width from $\frac{1}{8}$ " to $\frac{3}{8}$ " and up to $1\frac{1}{4}$ " deep, either with or across the grain. Made of the

finest steel, carefully hardened and tempered. Includes special $\frac{1}{8}$ " inside cutter. Fits 860, 1160 and 1450 saws.

No. 333 6" Dado Head, consisting of two outer blades, $\frac{1}{8}$ " thick, two inside cutters $\frac{1}{8}$ " thick, one inside cutter $\frac{1}{4}$ " thick and one $\frac{1}{8}$ " thick. To cut grooves from $\frac{1}{8}$ " to $\frac{3}{8}$ ", advancing by $\frac{1}{8}$ ". With $\frac{5}{8}$ " holes to fit No. 860 and 1160 Circular Saw..... **\$10.75**
Shipping Weight $3\frac{1}{2}$ lbs. Code Word EICDA.

No. 874 Table Insert for No. 860 Circular Saw..... **.90**
Shipping Weight $1\frac{1}{2}$ lbs. Code Word NEEDA.

No. 1161 Table Insert for No. 1160 Saw..... **\$1.10**
Shipping Weight $1\frac{1}{2}$ lbs. Code Word TENSF.

No. 1452 Table Insert for No. 1450 Saw..... **\$1.20**
Shipping Weight $1\frac{3}{4}$ lbs. Code Word TILTC.

MOULDINGS In Hundreds Of Different Shapes Made On Your Saw By Means Of This Inexpensive Attachment

DOES MARVELOUS WORK!

This unique attachment (U. S. Pat. No. 1,830,813) is the only practical tool of its kind. It consists of a strong, well-designed head, which may be had either in light-duty or heavy-duty type. A set of three interchangeable knives is locked into the head so that they are completely safe in operation. The head may be used either on the 860, 1160 or 1450 circular saw, or on most other saws provided with a double-face fence.

A perfect moulding may be produced with one pass over the knives, or, if the cut is a deep one, in two or more passes. The attachment is such a practical one that it is used in hundreds of production shops, yet it is priced within the reach of every small shop. A special solid-steel head

is available for production or heavy-duty work.

There is nothing to get out of order in this tool, and it is extremely safe in operation because only the actual cutting edges of the knives are exposed, and even this is covered when the work is being run. Enthusiastic users tell us that it makes their saws into first-class moulding machines!

As seen at the right, the knives may be used singly or in combination to produce almost any type of exterior, interior or cabinet mouldings. This illustration shows only a few of the hundreds of moulding shapes that have been produced with this wonderful tool.

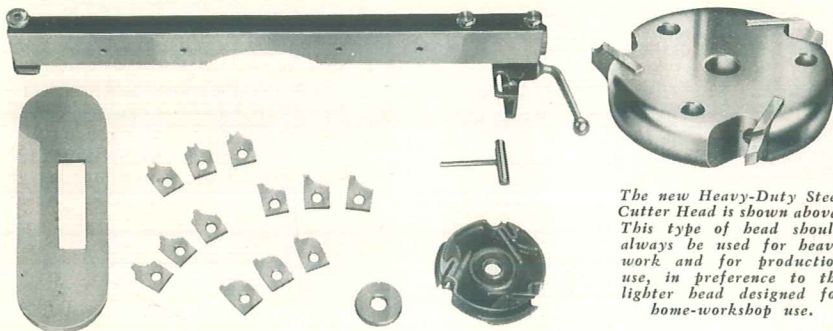

The new Heavy-Duty Steel Cutter Head is shown above. This type of head should always be used for heavy work and for production use, in preference to the lighter head designed for home-workshop use.

The knife shapes (originated by us) are so designed that hundreds of shapes can be made with only four sets of knives, as shown to the right. Additional knives are available as below.

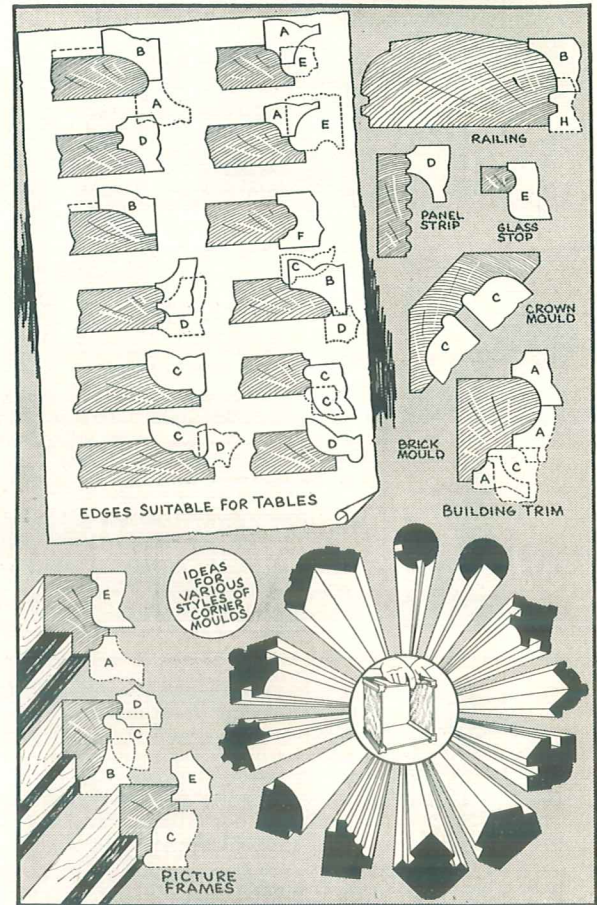

Light-Duty Moulding Cutter Sets

No. 858 Moulding Cutter Set, to fit $\frac{5}{8}$ " arbor of No. 860 circular saw. Complete with four sets of high-speed cutters, styles A, B, C and D, oval table insert, micro-guide fence, collar, wrench and complete instructions **\$15.55**
Ship. Weight 10 lbs. Code Word MOLDY.

No. 262 Moulding Cutter Set for other makes of circular saws with arbor up to $\frac{7}{8}$ " diameter. Price includes boring up to $\frac{1}{2}$ ", $\frac{5}{8}$ ", $\frac{3}{4}$ " or $\frac{7}{8}$ " diameter. Does not include table insert or guide fence. Specify bore wanted **\$11.90**
Ship. Weight. 3 lbs. Code Word MOUJH.

No. 1169 Moulding cutter set for No. 1160 Circular Saws. Same as No. 858, but without fence (wood facings are used on standard fences of these saws when moulding cutter is used) **\$12.50**
Ship. Weight 8 lbs. Code Word TENMC.

No. 1456 Light-duty Moulding Cutter Set for No. 1450 Circular Saw, with light-duty head, 4 sets of cutters, table insert, collar and wrench **\$12.60**
Ship. Weight 8 lbs. Code Word TILTG.

No. 868 Moulding Cutter Fence, 20 $\frac{3}{4}$ " long, complete as shown above for No. 860 saw.. **\$3.50**
Ship. Weight 7 lbs. Code Word NECFE.

Heavy-Duty Moulding Cutter Sets

No. 859 Heavy-Duty Moulding Cutter Set for No. 860 Circular Saw. Same as No. 858, $\frac{5}{8}$ " bore, but with heavy-duty steel cutter head, without collar **\$17.30**
Ship. Weight 12 lbs. Code Word MOUHL.

No. 267 Heavy Duty Moulding Cutter Set. Same as No. 262, but with heavy-duty steel cutter head, without collar **\$13.65**
Ship. Weight 5 lbs. Code Word MOUHK.

No. 1158 Heavy-Duty Moulding Cutter Set No. 1160. Same as No. 1169, but with heavy-duty steel cutter head, without collar. **\$14.25**
Ship. Weight 10 lbs. Code Word MOUHM.

No. 1458 Heavy-Duty Moulding Cutter Set for No. 1450 Circular Saw. Same as No. 1456, but with heavy-duty head; without collar **\$14.35**
Ship. Weight 10 lbs. Code Word TILTJ.

All heavy-duty heads $\frac{5}{8}$ " bore. Extra for $\frac{3}{4}$ " or $\frac{7}{8}$ "75

Extra Cutter Heads and Inserts

No. 249 Moulding Cutter Head only, with screws, to fit $\frac{5}{8}$ " arbor, with collar. Does not include wrench or cutters. **\$2.10**
Extra for boring $\frac{1}{2}$ ", $\frac{3}{4}$ " or $\frac{7}{8}$ "... .75
Ship. Weight 18 oz. Code Word MOUHA.

No. 265 Heavy-Duty solid-steel head only, to fit $\frac{5}{8}$ " arbor. Without wrench or cutter. **\$3.85**
Not furnished in $\frac{1}{2}$ " bore
Extra for boring $\frac{3}{4}$ " or $\frac{7}{8}$ "75
Ship. Weight 3 lbs. Code Word MOUST.

No. 872 Moulding Cutter Insert only, to fit No. 860 circular saw **\$.95**
Ship. Weight 1 $\frac{1}{2}$ lbs. Code Word NECIO.

No. 1162 Moulding Cutter Insert for No. 1160 saw **\$1.10**
Ship. Weight 1 $\frac{1}{2}$ lbs. Code Word TENSJ.

No. 1453 Moulding Cutter Insert for No. 1450 saw **\$1.20**
Ship. Weight 1 $\frac{1}{2}$ lbs. Code Word TILTJ.

No. 1521 Wrench **\$.15**
Sh. Wt. 6 oz. WRENB.

No. 245 Collar **\$.15**
Sh. Wt. 6 oz. COLLA.

Extra Sets of Cutter Blades

Cutters come in sets of three matched blades. Being made of high-speed steel (not carbon steel) they will cut thousands of feet of moulding before dulling. All these knives may be used with shaper cutter head No. 1343 listed on Page 19.

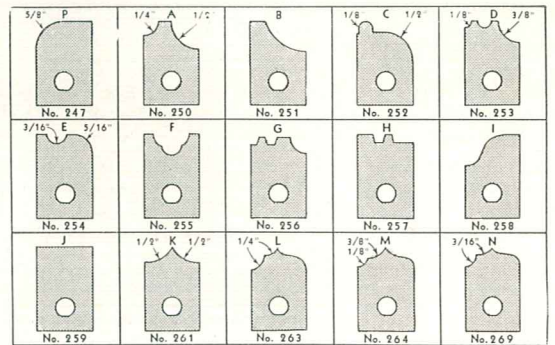

No.	Style	Description	Code	Price Set
247	P	Cove	MOULP	\$2.25
250	A	Bead	MOULA	2.25
251	B	Bead	MOULB	2.25
252	C	Crown Mould.	MOULC	2.25
253	D	Panel Strip	MOULD	2.25
254	E	Glass Stop	MOULE	2.25
255	F	Screen Mould	MOULF	2.25
256	G	Drawer Joint	MOULG	2.25
257	H	Glue Joint	MOULH	2.25
258	I	O-G Curve	MOULI	2.25
259	J	Straight	MOULJ	2.25
261	K	Flute Bead	MOULK	2.25
263	L	Flute & Cove Comb.	MOULL	2.25
264	M	Flute & Cove Comb.	MOULM	2.25
269	N	Flute & Cove Comb.	MOULN	2.25

MORE FOR YOUR MONEY: You Get More For Your Money

When You Buy One Of Our Jointers

Here Are Some Of The Reasons Why:

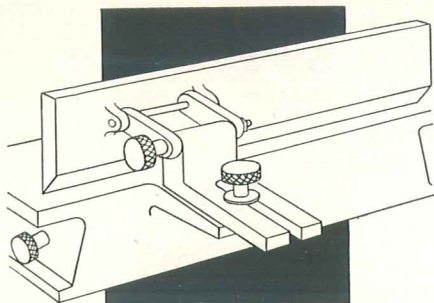

On older-type fences, adjustments for the fence are usually at the back of the fence, awkward to handle and hard to adjust exactly.

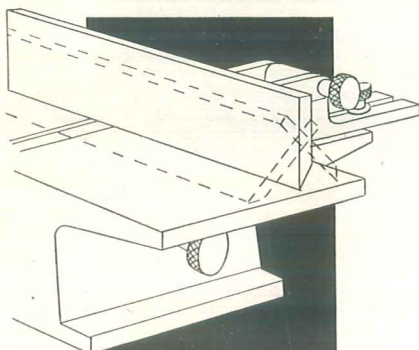

On older-type fences, the bottom of the fence swings in or out when tilted, requiring re-setting of the entire fence for many operations. On many fences, the fence cannot be swung "in" at all.

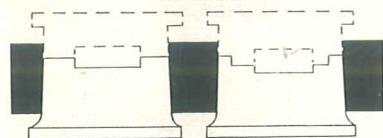

Some jointers have plain machined ways to carry the table, and some have plain rabbeted ways. Neither design provides any takeup for wear.

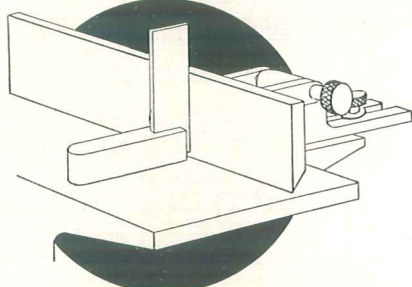

Due to the absence of stops on old-type fences, the square must be used to re-set the fence vertically every time the fence is tilted.

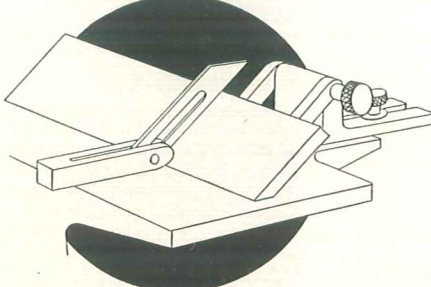

On old-type fences, it is also necessary to use a bevel gage or other angle gage every time the fence must be set to 45 degrees for miter work.

If we told you that we probably have more experience in manufacturing GOOD small jointers than anyone else in the world, it would be true, so far as we know—but it wouldn't mean very much. Even the "oldest manufacturer" in any field can go to sleep on his feet, and when he does, his past experience means nothing to the purchaser of his machines.

But when, in addition to years of experience in building GOOD jointers, a manufacturer is alert to every opportunity of improving his machines, of building into them even greater value, of making them more accurate, of increasing their convenience, of giving you more for your money—then his vast experience IS of importance to you.

When you buy one of our 4" or 6" jointers, you buy the result of years of experience in building GOOD machines. You buy the result of years of experience in accurate workmanship, in advanced engineering. You buy the result of years of research, study and contact with thousands of jointer users. You buy—so far as it is humanly possible for us to insure it—thorough SATISFACTION!

Study the Drawings

The illustrations on this page point out some of the differences between our jointers and others. But this is only a part of the reason for the superiority of our machines. There are other reasons, unseen, but important. Take machining, for example. We are not content merely to rough-bore and ream the seats for the ball bearings, although this might be "good enough." We diamond-bore these seats, to insure absolute accuracy.

The tables of our jointers are first rough-machined, singly. The machine is then carefully assembled with the tables mounted on the base, and both tables are then carefully and accurately finish-ground. This insures that the tables will be perfectly aligned, and, although it involves a number of additional operations, we consider it necessary for accuracy and for your satisfaction. Similarly with all other operations. You will find no skimping—no shoddy workmanship in our jointers.

Study the drawings and the illustrations on the following pages, and you will readily see why you should have one of these jointers in your shop.

Thorough Engineering, Careful Design and Accurate Machining Assure You Good Machines

Aside from the advantages of the patented features of the machines themselves, there are many other reasons why it pays you to buy our jointers. Consider their self-sealed ball bearings—lubricated for life (not merely "dust-sealed"). Consider their thorough engineering, their careful, painstaking de-

sign, even in small details, the high-grade and accurate workmanship in every part. Compare them with other machines from every angle—price, capacity, appearance, design or workmanship—and you will understand why men who know good craftsmanship prefer these jointers for their work.

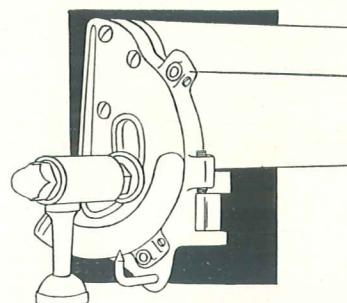

On our fences, both adjustments are at the front, combined in one simple, convenient control handle, providing fast, accurate adjustment.

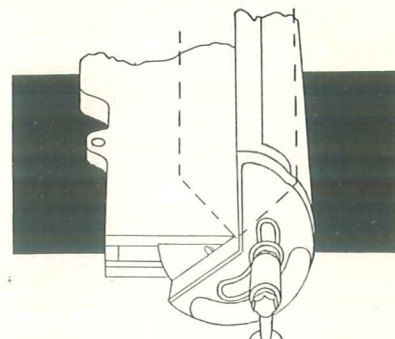

On our fences, the bottom does not swing either in or out when tilted. This provides full table capacity for angular work—and the fence tilts both ways.

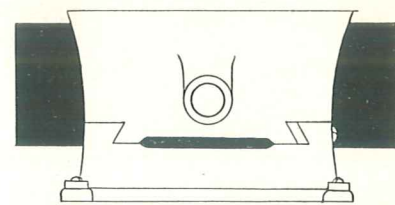

Our tables employ the finest type of mounting, with accurately machined dovetail ways, provided with gib and adjusting screws to take up wear.

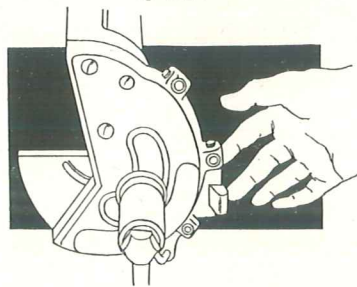

On our fence, once the stops at 45 and 90 degrees have been set, there is never again any necessity to use the square or bevel. A flip of the finger takes the stop out of the way for tilting.

SAVES ITS COST In a Small Shop In a Remarkably Short Time

**FINEST VALUE EVER OFFERED
FOR REAL CRAFTSMEN!**

6" JOINTER

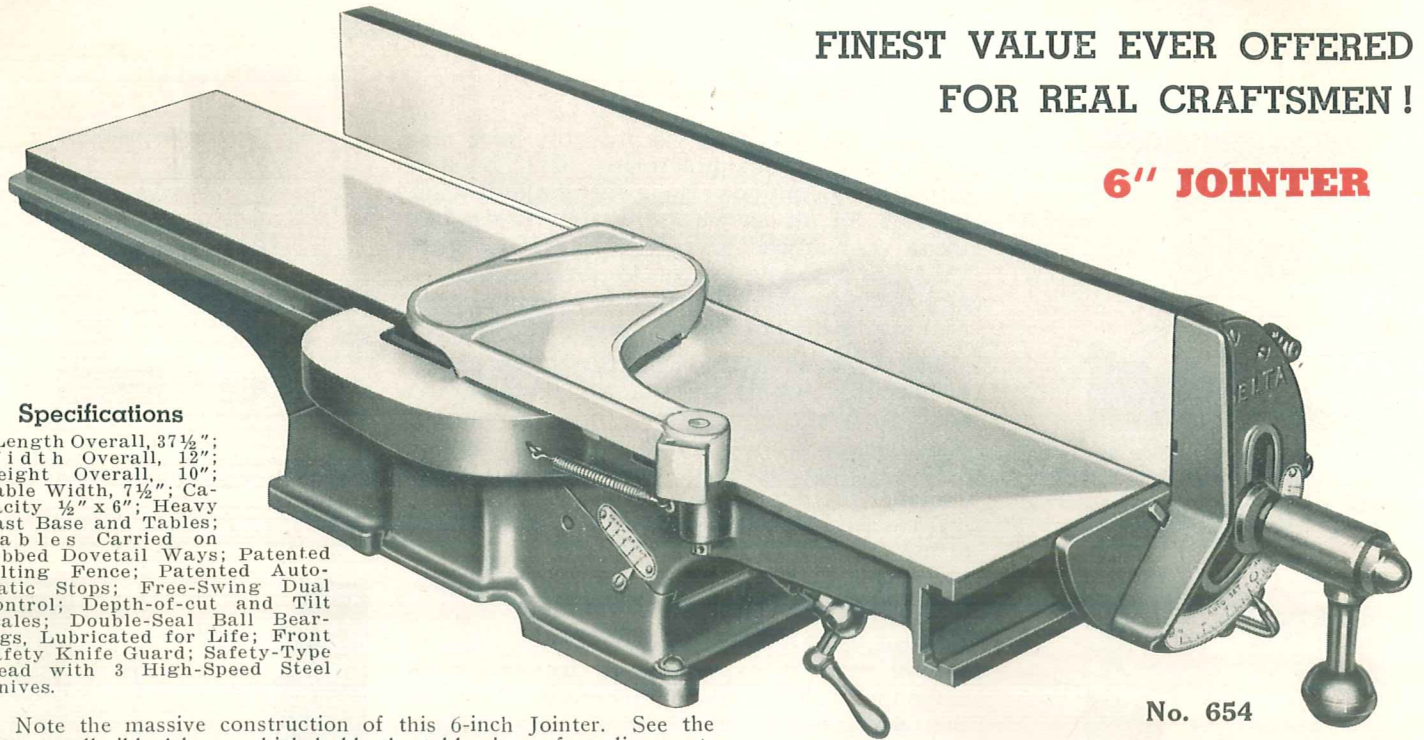

No. 654

Specifications

Length Overall, 37½";
Width Overall, 12";
Height Overall, 10";
Table Width, 7½"; Capacity ½" x 6"; Heavy Cast Base and Tables; Tables Carried on Gibbed Dovetail Ways; Patented Tilting Fence; Patented Automatic Stops; Free-Swing Dual Control; Depth-of-cut and Tilt Scales; Double-Seal Ball Bearings; Lubricated for Life; Front Safety Knife Guard; Safety-Type Head with 3 High-Speed Steel Knives.

Note the massive construction of this 6-inch Jointer. See the heavy, well ribbed base, which holds the tables in perfect alignment. Note the extremely rigid fence—a fence which cannot possibly spring sidewise as work is fed through. Note the heavy construction of the fence bracket and slide. You will then understand why this jointer produces such accurate work.

Careful machining, in addition to massive design, aids in producing precision work. The tables are not only ground flat and true individually, but, after assembly, they are ground at the same time on a larger grinder—no chance of any lack of alignment.

The fence tilts on our patented bracket, insuring sure, free action, and unvarying accuracy of the stop settings—something very difficult to achieve in machines without our principle. The swinging stop, with its individually adjustable stop screws at the 45, 90 and 135-degree positions, insures that, once the stop screws are accurately set, the double-tilting fence will invariably return to the same accurate setting after tilting. Once set, the fence is always set for these most frequently used positions.



No. 660

And the dual-control handle: Slid in, it engages the tilting lock and a twist of the wrist tilts the fence. Slid out, it engages the bracket lock, enabling the whole fence to be moved across the table. In the center, it swings free, completely out of the way of the operator.

THESE PATENTED FEATURES INSURE

THESE FEATURES APPLY TO BOTH JOINTERS

When the dual-control handle is slid out it engages the bracket lock nut, which when loosened (by a twist of the wrist), frees the entire fence so that it can be moved across the table to any position desired. Tightening the nut, clamps the fence firmly and accurately in position.



When the dual-control handle is slid in it engages the tilting lock nut. A twist of the nut loosens the quadrant so that the fence may be tilted to any angle desired. Tightening the nut locks the fence. When the handle is not engaged it swings free, out of the way.

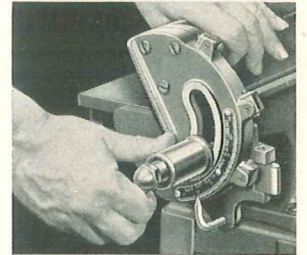

A touch of the finger moves the patented stop links into or out of engagement with the individually adjustable stop set screws enabling the fence to be accurately stopped at 45, 90 or 135 degrees. The fence can be set accurately for other angles by means of large tilt scales.

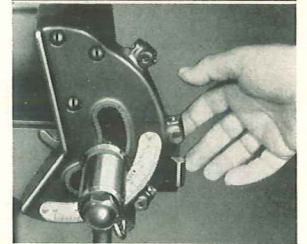

To insure absolute accuracy when tilting the fence the stop screws are individually adjustable. This is another patented feature which makes the jointers the favorite of the real craftsman and insures that once the stops are set, the fence will always return to its setting.

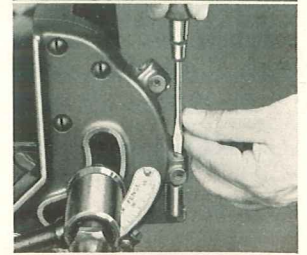

No. 654 Patented 6" Ball-Bearing Jointer, with set of three High-Speed Steel Knives, 2-Way Tilting and Graduated Fence with Dual Control, 2¼" arbor pulley and front safety guard Without motor, belt or motor pulley. Ship. Wt. 120 lbs. Code Word SIXJO... **\$48.85**

No. 660 6" Jointer Unit consisting of No. 654 Jointer, No. 560 V-Belt, No. 5700 7" V-Pulley, No. 656 Steel Stand. Less motor, belt guard and switch rod Shipping Weight 154 lbs. Code Word SIXUN. **\$57.90**

Note: For regular use, specify No. 6400 motor and No. 1333 switch rod. For school and production use, specify No. 6600 three-phase motor. See pages 28-30 for prices.

No. 560 V-belt, 22¾" center to center, (Use No. 510 Belt for combination units) Shipping Weight 1 lb. Code Word EICVB. **\$1.00**

No. 5700 V-pulley, drives jointer at correct speed (4200 R.P.M.). ½" bore furnished unless otherwise specified. Ship. Wt. 2 lbs. Code Word PULOL... **\$1.20**

No. 659 Extra set of three high-speed steel knives. Ship. Wt. 6 oz. Code Word SIXKI... **\$3.30**

No. 656 Steel Stand for 6-in. Jointer (8" wide, 15½" long, 29½" high). Ship. Wt. 31 lbs. Code Word SIXST **\$6.85**

No. 661 Belt guard for 6-in. Jointer, with stud screws, etc. Ship. Wt. 33 lbs. Code Word SIXGA... **\$7.85**

No. 662 Rear knife guard for 6-inch Jointer with spring. Ship. Wt. 2 lbs. Code Word SIXRE.. **\$3.75**

FINEST VALUE Ever Offered in This 4" Ball-Bearing Jointer

Every Convenience of the Famous 6" Jointer, for Those Who Require Only 4" Capacity

4" JOINTER

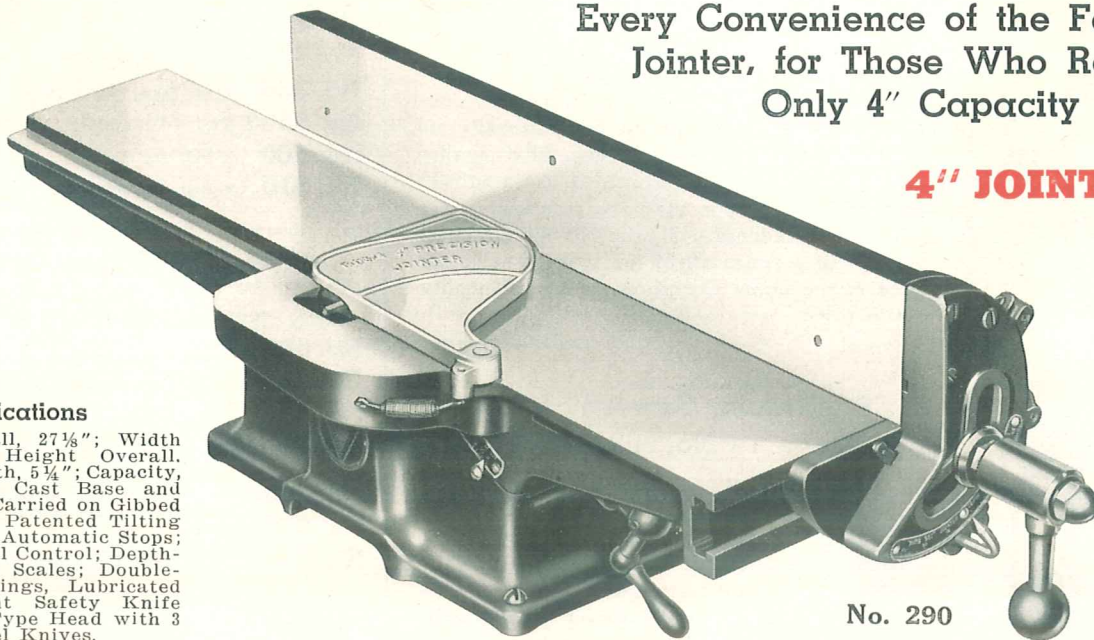

No. 290

Specifications

Length Overall, 27 1/8"; Width Overall, 9 5/8"; Height Overall, 9 5/8"; Table Width, 5 1/4"; Capacity, 1/4" x 4"; Heavy Cast Base and Tables; Tables Carried on Gibbed Dovetail Ways; Patented Tilting Fence; Patented Automatic Stops; Free-Swing Dual Control; Depth-of-cut and Tilt Scales; Double-Seal Ball Bearings, Lubricated for Life; Front Safety Knife Guard; Safety-Type Head with 3 High-Speed Steel Knives.

ACCURACY—LONG LIFE—CONVENIENCE

EXCEPT AS OTHERWISE NOTED

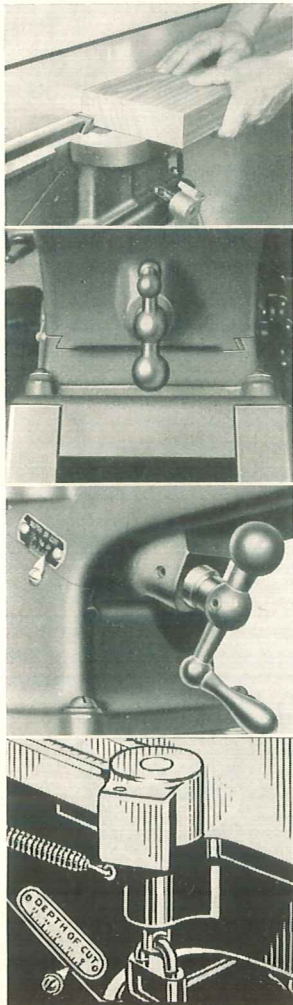

Rabbit cuts a full 1/2" on the 6" Jointer and a full 1/4" on the 4" Jointer can be cut at one pass of the work. The guard is instantly removed for rabbeting and just as quickly replaced—a feature welcomed in all shops because it wastes no time—no tools are needed.

View of the underside of the table showing the rigid construction of the husky base casting and the dovetailed ways on which the tables move. Notice the gib at the right permits adjustment for wear which means this jointer will always be accurate.

The convenient ball-crank handle allows front table to be raised and lowered in a jiffy. Plenty of room means no skinned knuckles. The scale at the side shows depth of cut which is a maximum of 1/2" on the 6" Jointer and 1/4" on the 4" Jointer—ample capacity for all work.

The flap guard on the 6" unit covering the knives may be locked to the machine with a padlock to prevent unauthorized removal of the guard—a very important feature in all shops. The 6" Jointer can also be fitted with a rear flap guard as listed which also may be locked.

The precision construction, built-in convenience and all around-handiness and accuracy of the No. 654 6" jointer—never before available in a jointer of this size—have led to an increasing demand for the same convenience and precision in a jointer of 4" capacity, and the result is the No. 290 jointer—the last word in tools of its size.

Every convenience and advantage of construction that have made the 6" jointer the standard in its class is incorporated in this new machine.

It is provided with the patented fence that insures sure, free action and unvarying accuracy of the settings. It has the patented swinging stop with its individually adjusted stop screws at the 90-degree and both 45-degree positions; it has the dual-control handle that makes control of the fence so convenient. The entire machine follows the same massive design that has made the 6" jointer such a success.

For those who require a machine for edge jointing and similar work up to 3/4" by 4", this machine will quickly prove its superiority over any other of similar size. Tables are extra long—front table 11 5/8", rear 14 1/4" and 27 1/8" long overall, to aid in producing accurate work.

Precision machining, in addition to massive design, aids in producing precision work on this machine. The tables are guided on dovetail ways, gibbed as in the most expensive machinery. Tables are ground flat and true individually, and then again after assembly, to insure perfect alignment. Nothing omitted that would add to precision or convenience.



No. 292

No. 290 4" Ball-bearing Jointer, with Two-Way Tilting and Graduated Fence with Dual-Control Handle, set of three high-speed steel knives, arbor pulley and front safety guard. Without motor, belt or motor **\$29.90**

Shipping Weight 75 lbs. Code Word JOIBM.

No. 292 4" Jointer Unit, consisting of No. 290 Jointer, No. 560 V-belt, No. 5650 6 1/2" V-pulley and No. 304 Steel Stand. Without motor or switch rod **\$38.25**

Shipping Weight 110 lbs. Code Word JOIBO.

Note: For regular use, specify No. 6400 motor and No. 1338 switch rod. For school and production use, specify No. 6600 three-phase motor. See pages 28 to 30 for prices. No belt guard available for this unit.

No. 5650 6 1/2" V-pulley, 1/2" bore **\$1.10**
Shipping Weight 1 1/2 lbs. Code Word PULOQ.

No. 560 V-belt, center to center, distance 22 3/4" **1.00**
Shipping Weight 1 lb. Code Word EICVB.

No. 304 Steel stand, with chute **6.25**
Shipping Weight 31 lbs. Code Word JOIST.

No. 302 Extra Set of 3 high-speed steel knives **2.75**
Shipping Weight 8 oz. Code Word JOIKI.

MANY ADVANTAGES In These Combination Saw-Jointer Units

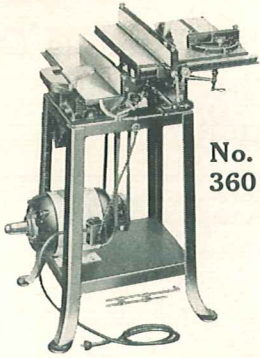

No. 360

8" Circular Saw—4" Ball Bearing Jointer, No. 360

The most popular Saw-Jointer unit we ever offered the home craftsman—due to its rugged construction—accuracy and capacity but especially its price. Although the jointer is generally smaller than the unit described on page 13 it has a 1/4"x4" capacity and is built upon the same principle of accuracy and ruggedness. A thoroughly practical unit which will perform all of the work usually encountered in the home workshop—a tool of quality yet low in price.

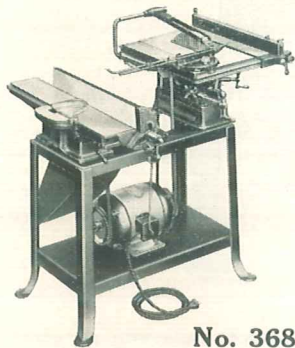

No. 368

8" Circular Saw—4" Jointer, No. 368

This combination unit utilizes the No. 290 Jointer shown on page 13 and the 8" circular saw. Supplied with a larger stand giving greater distance between the units. Available to the home crafter who wants a better machine with a slightly larger jointer with its refinements. Capacity jointer: 1/4"x4"; Saws 2 1/4" thick, 15"x18" table.



No. 1350

8" Circular Saw—6" Jointer, No. 1350

For those who need a larger jointer capacity this unit is available. No. 654 6" Jointer (described on Page 12) is used in conjunction with the 8" saw, No. 860. The ideal combination for the serious home crafter who makes units which require a real machine. Capacity Jointer: 1/2"x6"; Saw 2 1/4" thick, table 15"x18". See pages 12 and 7 for complete description of individual units.



No. 1164

10" Circular Saw—6" Jointer, No. 1164

Actually this combination has been developed for production purposes such as encountered in building, furniture manufacture and the wood specialty field. However, there are those home crafters who feel that their work is of such nature to warrant a machine of this kind. The best combination available. Capacity, Jointer: 1/2"x6"; Saw 3 1/4" thick. See pages 5 and 12 for complete description of units.

No. 360 Combination Unit Includes:

No. 860	8 inch Timken-Bearing Circular Saw	\$32.85
No. 301	4 inch Ball-Bearing Jointer....	23.85
No. 356	Steel Stand with Chute.....	7.50
No. 5500	Two V-Pulleys, 3/4" bore.....	1.50
No. 560	V-Belt for Saw	1.00
No. 510	V-Belt for Jointer	1.00

Total (less saw guard, motor & switch rod) .. **\$67.70**

Shipping Weight 170 lbs. Code Word COMBA.
No. 9000 or 8050 Motor recommended. Switch Rod No. 1334. See pages 28-30.

No. 368 Combination Unit Includes:

No. 860	8" Timken-Bearing Circular Saw	\$32.85
No. 290	4" De-Luxe Jointer, with guard	29.90
No. 361	Steel Stand, with chute and raising block	11.25
Ship. Wt. Stand and Block Only, 75 lbs. Code CROSSX.		
No. 5500	5" V-pulley for saw, 3/4" bore..	.75
No. 5650	6 1/2" V-pulley for jointer, 3/4" bore	1.10
No. 560	V-belt for saw	1.00
No. 510	V-belt for jointer	1.00

Total (less saw guard and motor).... **\$77.85**

Shipping Weight 243 lbs. Code Word COMBG.
Use No. 9000 or 8050 motor, and No. 1334 switch rod. See pages 28-30. Stand dimensions: 14" wide, 27 1/2" long, 26 3/8" high.

No. 1350 Combination Unit Includes:

No. 860	8" Timken-bearing Circular Saw	\$32.85
No. 654	6" Ball-bearing Jointer.....	48.85
No. 1356	Steel stand, with chute and raising block	13.25
Ship. Wt., stand and block only, 78 lbs. Code CROSU.		
No. 5700	V-pulley for jointer, 3/4" bore..	1.20
No. 5500	V-pulley for saw, 3/4" bore.....	.75
No. 510	V-belt for jointer	1.00
No. 560	V-belt for saw	1.00

Total (less saw guard, motor & switch rod) **\$98.90**

Shipping Weight 292 lbs. Code Word COMBE.
Use motor No. 9000 or 8050. Switch rod No. 1334. Stand dimensions: 16" wide; 30" long; 26 3/8" high.

No. 1164 Unit, Consisting of:

No. 1160	10" Circular Saw	\$55.85
No. 654	6" Jointer	48.85
No. 1168	Steel stand (16" wide, 30" long, 26 3/8" high)	11.85
Ship. Weight, Stand Only, 73 lbs. Code Word TENSO.		
No. 510	V-belt for jointer	1.00
No. 560	V-belt for saw	1.00
No. 5500	5" V-pulley for saw, 3/4" bore..	.75
No. 5700	7" V-pulley for jointer, 3/4" bore	1.20

Price without motor, switch rod or circular saw guard

\$120.50

Shipping Weight 386 lbs. Code Word TENSJ.
No. 9000 or 8050 motors recommended for this machine for ordinary use. For heavy duty and production use No. 9400, 9100 or 9200 3/4-H.P. and 1-H.P. motors are recommended. Use No. 1334 Switch Rod. See pages 28-30.

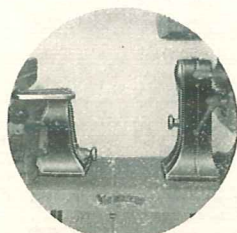

Belt Guards for Combinations

Adding still further to the safety of the 10" saw and 6" jointer in the No. 1164 combination unit, guards are now offered for the portions of the belts exposed above the top of the stands. Since the lower portion of stands are easily enclosed with wire mesh, these guards make it easy to have machines conform to industrial safety requirements.

No. 1176	Belt Guard for No. 1160 Circular Saw	\$3.75
Shipping Weight 10 lbs. Code Word TENSV.		

No. 1177	Belt guard for No. 654 Jointer.....	2.10
Shipping Weight 7 lbs. Code Word TENSW.		
(For use on No. 1168 stand only)		

Rubber Feet for Steel Stands

These feet for steel stands and bench legs will make your machines run smoother and quieter, an advantage where noise must be kept to the minimum. They are of the correct composition to stand hard usage, while having enough flexibility to absorb slight vibrations. Supplied with metal plates to fit in the recesses of our stand feet, and drilled and tapped for machine screws inserted from the top of the feet.

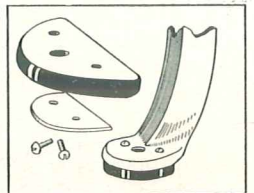

No. 353	Set of rubber feet, with plates and screws.....	\$.95
Shipping Weight 10 oz. Code Word RUBFE.		

REASONS WHY You Get So Much More For Your Money When You Purchase OUR SHAPER

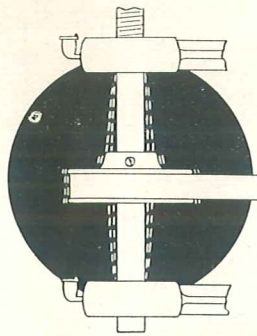

When shaper spindles are too light and the bearings comparatively far apart, destructive "whip" (shown exaggerated) develops at high speeds.

"Whip" is not only destructive to bearings, but sets up chatter in cutters. Many small shaper spindles must be lubricated through oil cups—not satisfactory for high-speed spindles.

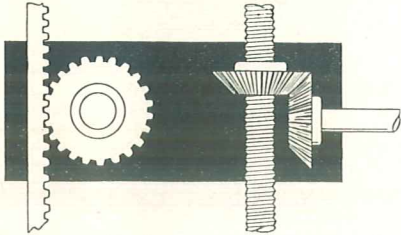

In many rack-and-pinion and screw actuated spindle-raising mechanisms, backlash makes accurate spindle setting hard to do quickly and accurately.

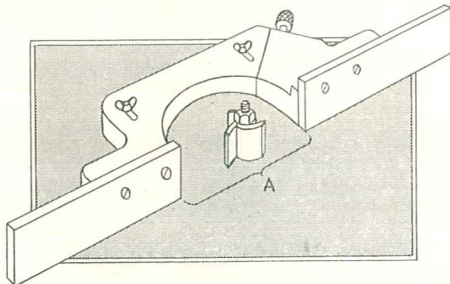

On most shapers only the front half of the fence is adjustable, and the non-adjustable fence faces leave a wide, dangerous opening around the cutter, as at "A".

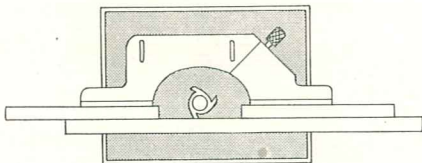

On most shapers, the first step in fence adjustment is to set the entire fence with both faces level and adjusted to the cutter cutting circle.

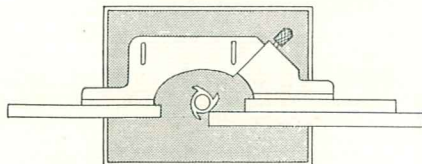

The next step, where the entire face of the moulding is to be cut away, is to set the front half of the fence to the correct depth of cut.

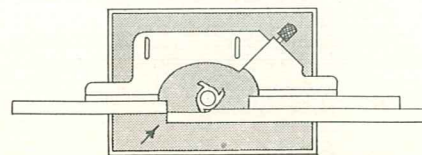

If the setting has not been exact, the work generally strikes the rear half of the fence, as indicated by arrow, and the whole setting operation must be done over again.

There are a number of reasons obvious to the experienced machine buyer why our shaper is used in hundreds of industrial, school and contractor's shops. Among these are its low cost—the wide range of the work it will handle—its availability in either bench or stand models—its thorough guarding—the low cost and wide variety of its cutters—the wide range of the work it will handle—its long life—its low power consumption.

But there are other reasons, hidden in the design of the machine, but none the less responsible for thorough satisfaction it is giving to users. Some of these are shown graphically on this page—others are inherent in the careful, painstaking machining of the parts (like the diamond-boring of the bearing seats). Others, again, require use of the machine to be appreciated.

Four Simple Operations Instead of Six Awkward Ones

For example, most shapers are fitted with fences on which only one-half is adjustable. As the drawings at the left show, when setting up straight work, three operations must be performed before the work is ready to run. In ninety cases out of a hundred, some re-setting of the fence is necessary when the last setting is reached—and with the ordinary shaper fence the complete setting must be done over again, because the whole fence must be moved to correct the inexact setting. With our fence, the rear half is adjusted in a few seconds, without disturbing the other settings, and the work is ready to run. A simple, exact procedure instead of an awkward, inexact one.

The difference in operation is even more pronounced whenever work must be done which requires the cutting away of the whole face of the work.

To do this on a fence with only the front half adjustable requires six operations, and requires the "juggling" of the whole fence and the front half until the setting is exact—a very clumsy operation.

On our fence, the settings for this kind of work are done in four simple, fast, easy operations, with no juggling—no guesswork.

Study the construction and operation of this shaper point by point. Contrast it with others at anywhere near its low cost, and you will see why many users call it "the most satisfactory small shaper on the market today!"

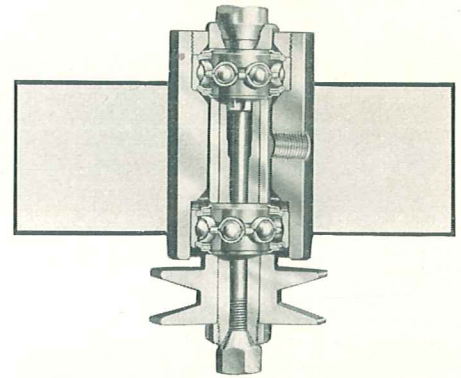

Our spindle drive, with short, stiff spindle and very closely spaced, preloaded bearings eliminating whip, produces chatterless work and requires no lubrication.

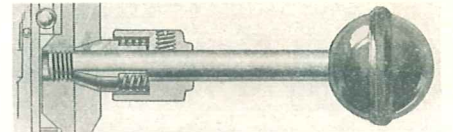

Our spindle height adjustment, with its spring-urged sleeve and tapered helical groove, eliminates backlash and makes accurate adjustment easy.

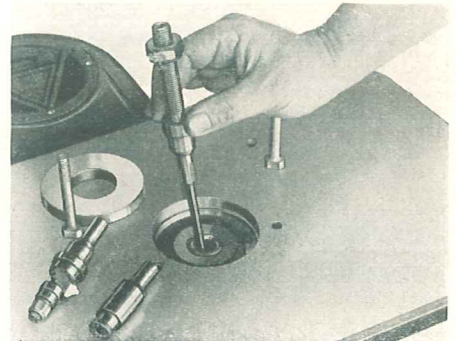

Interchangeable spindles permit use of wide variety of cutters, also stub spindle for cope cuts on sash and door and cabinet work.

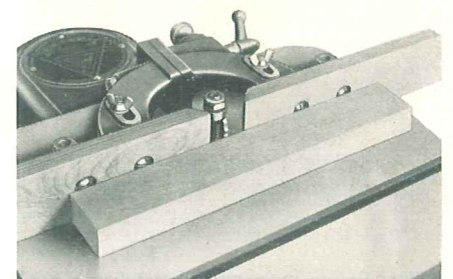

In our fence, both halves are adjustable through one control, and the fence faces—adjustable endwise—permit the cutter opening to be made as small as possible—a valuable safety feature.

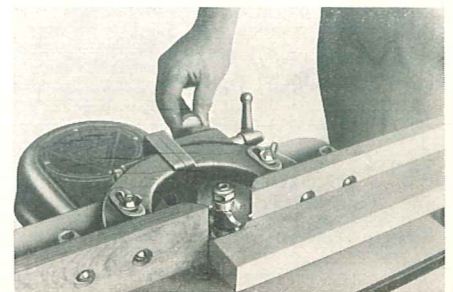

ASTONISHING VARIETY OF WORK Can Be Performed On This Shaper Built For the Professional and Amateur Craftsman

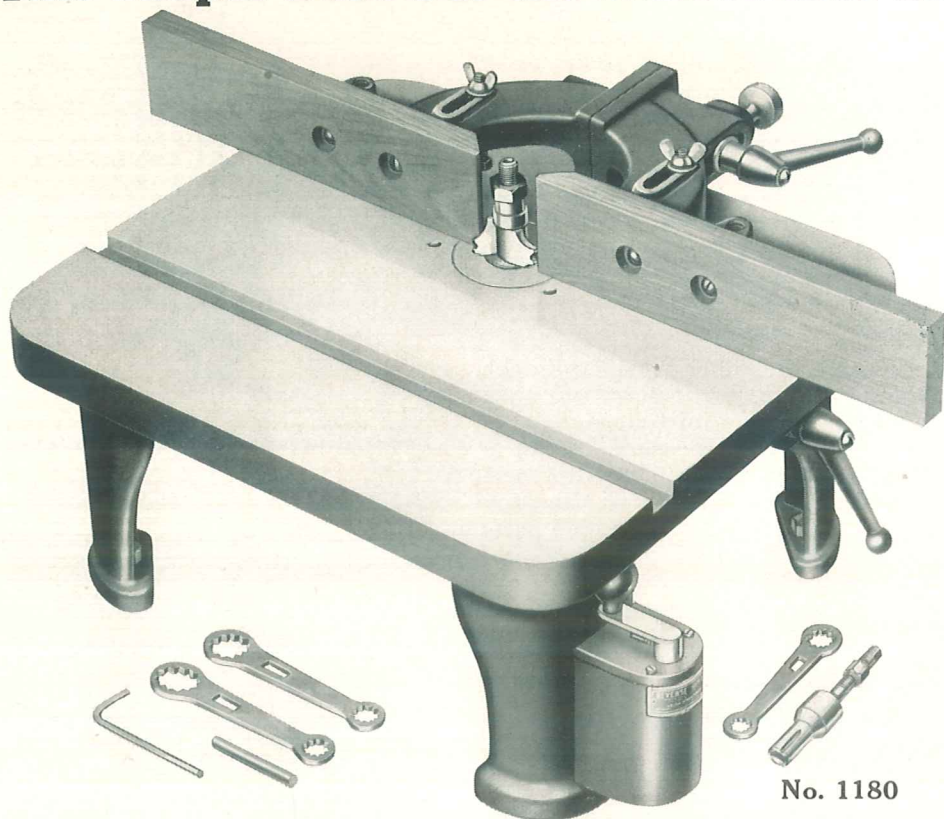

No. 1180

A MACHINE OF ASTONISHING VERSATILITY

Here is a bench shaper that embodies all the craftsman requires, whether he be professional or amateur. During the short time since it was introduced, hundreds of professional woodworking shops, from novelty shops to furniture manufacturers, have installed this machine as auxiliary to their larger shapers, and find that an astonishing variety of work can be performed with it.

It will make hundreds of mouldings using either $\frac{1}{2}$ " hole or $\frac{5}{8}$ " hole cutters. It will shape, form or mould the edges of almost any form of work that can be handled on a larger shaper; it will handle all of the window, storm and screen sash work of the average shop, and all of the cabinet work as well.

For ordinary work No. 6900 (old No. 915) reversible $\frac{1}{2}$ -H. P. motor is recommended. This is carried by a special bracket on the rear of the stand, carrying a guard which completely encloses belt and motor pulley. The front of the belt and the spindle pulley are enclosed by a separate guard, instantly removeable. Reversing switch for 6900 motor mounted on front shaper leg.

For production work No. 8100 (old No. 1075) 1-H.P. motor is recommended. This has a built-in reversing switch, and is provided with a snap-switch for mounting on the shaper leg as shown at the right. Both motors are 3450 r.p.m., and drive the spindle from a flat, flanged pulley which permits the spindle to be raised or lowered without strain or twist on the belt.

Specifications

Overall Dimensions
 25" Wide, 10 $\frac{1}{4}$ " High
 15 $\frac{1}{2}$ " Front to Back
 18" by 15 $\frac{1}{2}$ " Table
 25" Long Fence

Speed 10,000 R. P. M.
 5/16" and 1/2" Spindles

Spindle Carried in Double-Seal Ball Bearings
 (Requiring no lubrication for life of bearings)

Spindle Travel 3/4"

No-Backlash Spindle Adjustment

Spindle Height Lock
 3/8" x 3/4" Table Groove for Sliding Jig

Tapered Starting Pin

Leg Drilled for Reversing Switch

V-Belt Drive and Many Other Features

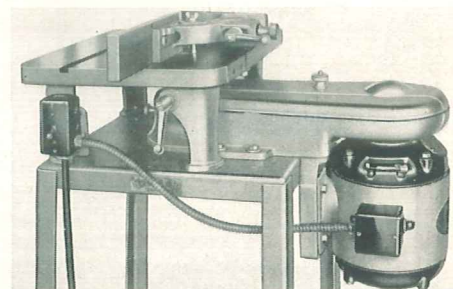

For heavy production work the 1 H.P. motor with built-in switch, as shown above, should be used.

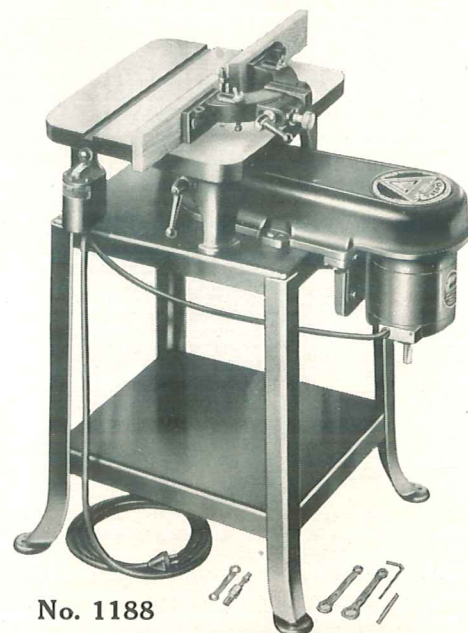

No. 1188

No. 1180	Ball-Bearing Reversible Shaper, with Fully Adjustable Fence $\frac{1}{2}$ " and $\frac{1}{2}$ " Spindles, Table Insert, Starting Pin, Wrenches and Spindle Pulley. Without Motor or Motor Pulley, Reversing Switch, Cutters or Collars	\$28.85
	Shipping Weight 57 lbs. Code Word SHAPR.	
No. 1185	Special flanged motor pulley, 5 $\frac{3}{8}$ " diam., $\frac{5}{8}$ " or $\frac{3}{4}$ " bore, with keyway, for standard 60-cycle 3450 r.p.m. motor (specify bore)..	1.55
	Shipping Weight 2 $\frac{1}{2}$ lbs. Code Word SHAPU.	
No. 1187	Flanged pulley as above, but 5 $\frac{7}{8}$ " diam., $\frac{5}{8}$ " or $\frac{3}{4}$ " bore, for 50-cycle 2850 r.p.m. motor. Ship. Wt. 2 $\frac{1}{2}$ lbs. Code Word SHAPL..	1.55
No. 410	Special flexible V-belt for shaper (do not use ordinary V-belt). Shipping Weight 10 oz. Code Word BELTB.....	.85
No. 430	Special V-belt for use with No. 1197 motor bracket and 1-H.P. motor. (Shipping Weight 10 oz. Code Word FORSL.....	.90
No. 1181	Steel stand (Top 16 $\frac{1}{4}$ "x18 $\frac{1}{4}$ "x26 $\frac{5}{8}$ " High).....	8.25
	Shipping Weight 51 lbs. Code Word SHAST.	
No. 1183	Belt Guard and Motor Bracket for $\frac{1}{2}$ -H.P. Motor.....	5.75
	Shipping Weight 28 lbs. Code Word SHABG.	
No. 1197	Belt Guard and Motor Bracket for 1-H.P. Motor.....	7.35
	Shipping Weight 30 lbs. Code Word SHAPV.	
No. 1188	Shaper Unit, consisting of No. 1180 Shaper, No. 1181 Stand, No. 1183 Belt Guard and Motor Bracket, No. 1185 Flanged Pulley and No. 410 V-Belt. Without motor or reversing switch, cutters or collars. Shipping Weight 176 lbs. Code Word SHAUN.....	45.25
No. 1199	Shaper Unit; same as No. 1188 but with No. 1197 Motor Bracket and No. 430 V-belt. Ship. Weight 178 lbs. Code Word SHAPW.	46.90

FOR LARGE TYPE PRODUCTION SHAPER SEE BACK COVER

END GRAIN SHAPING Is Fast, Easy, Accurate and Safely Done On This Shaper

Shaping of Short and Narrow Pieces Is Now a SAFE OPERATION

Striving always for complete safety in the operation of machines, our engineers have solved the problem of safe end-grain work, even on short and narrow pieces, by the design of the Sliding Jig for the shaper.

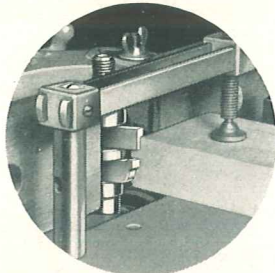

Photo at left shows how the jig is used on a sash operation, insuring absolutely accurate cuts. The photo at the right, below, shows how even a short, narrow block may be shaped safely by the use of the jig.

The jig consists of a ground plate, fitted with a key to slide in the groove in the shaper table. The plate carries the well-known Auto-Set miter gage head, which may be set at any angle and automatically stopped at 90 and 45 degrees.

Carried on top of the plate are two clamp rails, with screw clamps that may be slid to any position along the rails. When the work is clamped against the miter-gage head and against the plate, the whole jig is slid past the cutters.

The hands never come close to the cutters, and the work cannot slip. This means not only perfect safety but also much more accurate work.

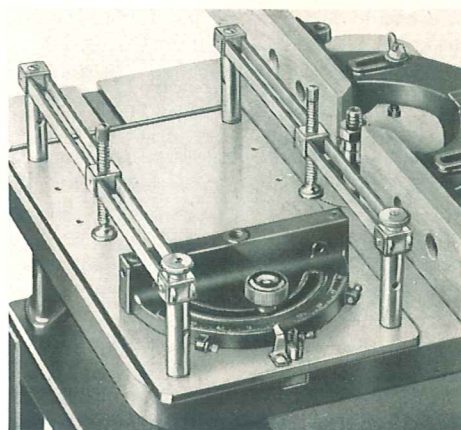
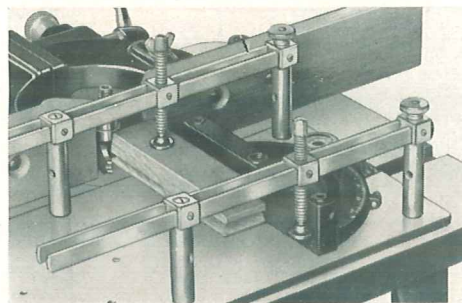

Photo above shows the jig for end-grain shaping from the right side of the machine, showing the stop and pointer on the miter-gage head.

Work Cannot Slip

The shaping of end grain work, especially when short or narrow pieces must be worked, as when "returning" the end of a moulding, has always been dangerous, because the narrow end, not having much bearing against the fence, is apt to be caught by the cutters and thrown out. This cannot happen when the sliding jig is used, because the work cannot slip and become caught.

For school work, or where inexperienced operators must be used, this feature of the jig is invaluable.



No. 1186 Sliding Shaper Jig, with ground base plate, fitted with miter-gage head and swinging stop link, four clamp-rail posts, four clamp rails and two clamp screws. To fit No. 1180 shaper **\$8.50**
Shipping Weight 13½ lbs. Code Word SHJIG.

No. 873 Additional clamp screw, with block, each..... **.45**
Shipping Weight 4 oz. Code Word NECCS.

Note: This sliding jig may be adapted to many other machines and for many other operations. Key on base plate is ⅜" by ¼".

Fully Adjustable SHAPER FENCE Is Marvel of Convenience

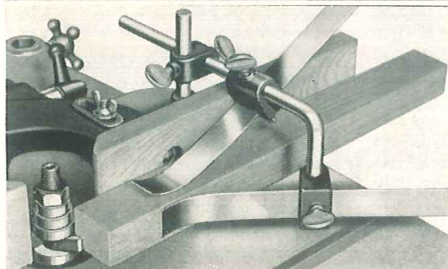
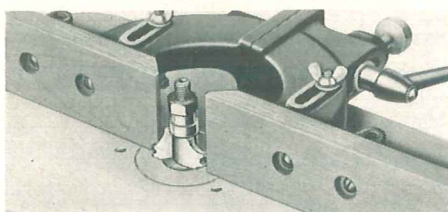

Not only thoroughly safe to use, but unequaled in ease of operation, convenience of design and accuracy of adjustment, the No. 982 shaper fence (U. S. Pat. No. 1,947,885) is the best type available to the user of small shapers. For ordinary shaper work the two faces of the fence are set in line, while for jointing or for work where all the edge of the material is cut away, one face of the fence may be adjusted forward to support the stock as it leaves the cutter. Each section of the fence may be adjusted forward or backward independently—and locked by a clamp lever which may be set at any angle to suit the operator.

The No. 982 Safety Shaper Fence is standard equipment on the No. 1180 Shaper, and is designed to fit the No. 989 and No. 999 drill presses also. It can be used on any type of shaper, and is actually more massive and much more convenient than many fences supplied on many heavy production shapers.

Spring hold-downs, available for use with the fence, add much to the convenience of operation. They hold the work not only

against the fence but also against the table. They can be used on either end of the fence, and are provided with universal brackets and long, flexible springs that accommodate work up to 3½" thick.

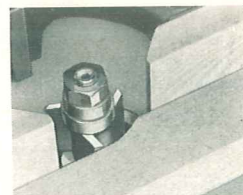

No. 982 Patented Shaper Fence to fit No. 989 and 999 drill presses, complete with wood facings, bolts and wingnuts, similar to standard fence on 1180 shaper **\$7.50**
Shipping Wt. 12 lbs. Code Word NESSF.

No. 983 Set of Shaper Hold-Downs, with straight and bent posts, two springs, two spring brackets, and one post bracket, for use with No. 982 shaper fence **\$2.00**
Shipping Wt. 2 lbs. Code Word NESHD.

DEMOUNTABLE GUARD Protects User on Curved and Circular Work



Shaping a curved rail with the No. 987 guard in place. Note how completely the knives are covered.

While no more thoroughly guarded shaper than the No. 1180 is available today, with its complete belt guards and safety fence, the fence cannot be used on circular or curved work. For this, the No. 987 Shaper Guard should be used. This guard is not standard equipment, but may be purchased as an extra. It fits not only the No. 1180 shaper, but also the No. 989 and 999 drill presses, when these are used as shapers with the ⅜" cutters.

The guard is fully adjustable, and completely protects the operator from accidental contact with the revolving cutters, besides acting as a hold-down for the work. It is instantly removable, and does not interfere with the work.

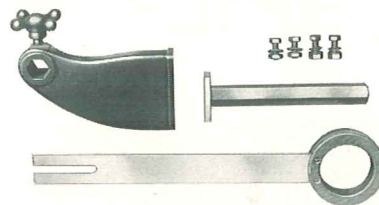

No. 987 Shaper Safety Guard for curved work, complete with bracket for shaper table, adapter bracket for drill-press wood table (not shown), hexagon post, spring bar with guard ring and screws **\$4.35**
Shipping Weight 8 lbs. Code Word NESGA.

SHAPER CUTTERS In A Wide Variety Of Shapes Meet All Requirements

STANDARD UNIVERSAL THREE-LIP CUTTERS

Literally hundreds of moulding shapes can be produced with the standard moulding-cutter shapes originally developed by us. They are now available in a high-grade three-lip shaper cutter, together with other shapes that further add to their convenience and utility.

Made of chrome-vanadium steel and hardened in oil, these cutters can be re-sharpened again and again merely by grinding across the faces of the cutting lips. Since they have involute relief, the sharpening does not change their shape, and the relief permits a true shaving cut while leaving a strong, well-supported edge on the cutter.

Collars for use with these cutters are ground to size, not merely rough-turned, so that they run perfectly true and will not score the work.

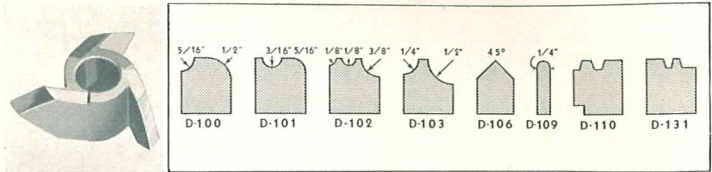

LIST OF STANDARD CUTTERS	
D-100 Cutter as shown.....	\$1.10
D-101 Cutter as shown.....	1.10
D-102 Cutter as shown.....	1.10
D-103 Cutter as shown.....	1.10
D-104 Straight Cutter, 1" wide	1.10
D-105 Straight Cutter, 1½" wide	1.50
D-106 45° Cutter	\$1.10
D-107 Straight Cutter, ½" wide	1.10
D-108 Straight Cutter, ¾" wide	.85
D-109 Round Nose, ¼" wide...	.85
D-110 Drawer Joint Cutter.....	1.35
D-111 Glue Joint Cutter.....	1.35
D-112 Wood Box with Slide Lid	.35
Approximate Shipping Weight of Cutters, 5 oz. each.	

LIST OF STANDARD CUTTER AND COLLAR SETS	
No. 1182 Set of Standard Shaper Cutters consisting of one each Cutters No. D-100, D-101, D-102, D-103, D-104, D-105, D-106, D-107, D-108, D-109, and eight suitable Spacing Collars, ranging from ¾" dia. to 1¾" dia. Packed in neat slide-top wood box. (Shipping Weight 3½ lbs. Code Word SHACU) ..	\$11.90

LIST OF STANDARD COLLAR SETS ONLY	
These collar sets consist of an assortment of Standard Collars increasing in size by sixteenths inches. Collars ¾" thick with ½" hole.	
No. 1210—Set of Seven Collars from ¾" dia. to 1¾" dia.	\$1.00
Shipping Weight ¾ lb. Code Word SHASU.	
No. 1211—Set of Six Collars from 1-⅜" dia. to 1½" dia.	1.25
Shipping Weight 1 lb. Code Word SHASV.	
No. 1212—Set of Six Collars from 1-⅝" dia. to 1¾" dia.	1.60
Shipping Weight 1½ lbs. Code Word SHASW.	

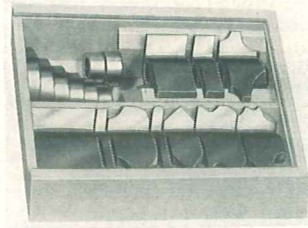
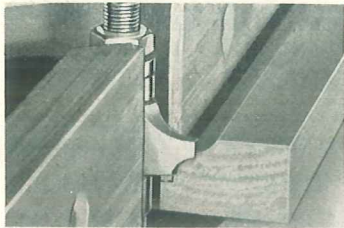

SASH AND CABINET CUTTERS Offer New Possibilities for Pleasure and Profit

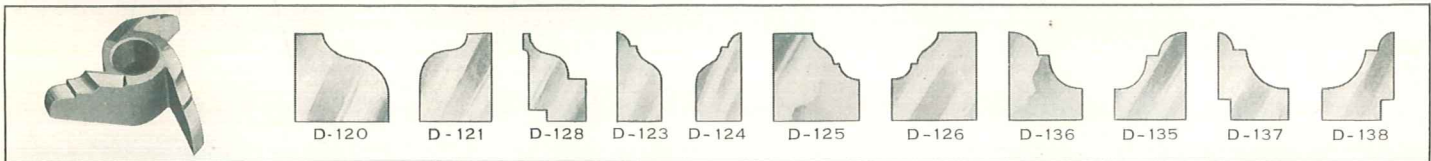

Above is shown special sash cutter D-128, with stub spindle, making cope cut on sash rail.

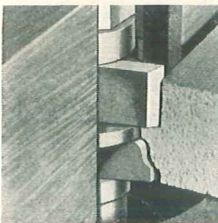

Making a combination rabbet and ogee cut on sash stock, using a spacing collar between cutters.

Here is a cutter development that offers unusual possibilities, not only for the man who likes to turn his home shop to the making of things useful as well as ornamental, but for the professional shop as well. With these cutters all the difficult cope and reverse mould shapes used on regular professional sash and cabinet work can be accomplished with ease.

With these, the owner of the No. 1180 shaper or any other shaper having a ½" spindle to which they can be adapted, is practically independent of the mill. He can make his own sash mouldings, door mouldings, doors for buildings or cabinet work, cabinet mouldings of all kinds, and all types of building trim, such as brick moulds, base moulds, back bands, etc., straight or circular. There is practically no limit to the amount of mill work he can do with both sets of cutters on hand. Sash cutters are designed for sash using

1⅛" to 1¾" stock. They can be used for many other purposes besides those briefly mentioned above.

Sash and Cabinet Cutters and Collars

D-120 Ogee cutter	\$1.10	D-135 Cove & bead, l. h. cut'r.	\$1.10
D-121 Female sash cutter	1.10	D-136 Cove & Bead, r. h. cut'r.	1.10
D-122 Male sash cutter (cope).	1.10	D-137 Cove & bead, r.h. cope cut.	1.10
D-123 Cabinet cut'r, r. h. male	1.10	D-138 Cove & bead, l.h. cope cut.	1.10
D-124 Cabinet cut'r, l. h. male	1.10	D-139 ¼"x2-⅝" straight cut....	.85
D-125 Cabinet cut., r. h. female	1.10	D-140 ¼"x1-⅝" Spacing collar.15
D-126 Cabinet cut., l. h. female	1.10	D-141 ⅝"x1-⅝" Spacing collar.15
D-127 ⅝"x1-⅝" straight cut....	.85	D-150 ⅝"x1-⅝" Spacing collar.20
D-129 ⅝"x2-⅝" straight cut....	.85	D-151 ¼"x1-⅝" Spacing collar.20
D-130 Str. sash cut., ¾" wide.	1.10	D-154 Wood box with slide cov.35
D-132 ⅝"x1-⅝" collar15	1190 Stub spindle, with Screw and Allen wrench.....	1.15
D-134 ¼"x1-⅝" collar15		

No. 1184 Set of Sash and Cabinet cutters, consisting of D-108, D-120 and 121, D-123 to D-128 inclusive, D-130 Plain cutter, Spacing Collars D-140, D-141, D-150 and D-151, with No. 1190 Stub spindle and wrench, packed in neat slide-top wood box.....	\$11.90
Shipping Weight 3 lbs. Code Word SHACB.	

COVE AND BEAD CUTTERS for Sash, Doors, Etc.

At the request of many users, we have added a set of cutters for the popular cove-and-bead moulding on sash, doors, etc. The cutters for the straight mouldings are D-135 and 136, shown above, and the right and left-hand cope cutters are D-137 and 138. Prices of individual

cutters, together with the D-139 straight cutter and D-132 and 134 collars, required for sash work, are shown in table above. Price of complete set shown below.

No. 1178 Set of cove-and-bead cutters, consisting of cutters D-129, D-135 to 139 inclusive, D-132 and 134 spacing collars. With stub spindle.....	\$7.55
Packed in Cardboard Box.	
Shipping Weight 2 lbs. Code Word SHAPY.	

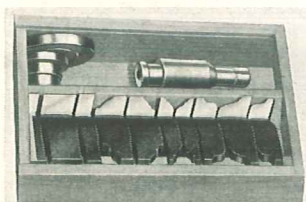

No. 1184 Set of Sash and Cabinet Cutters, Collars, Spindle and Wrench, in wood box.

ADDITIONAL SHAPES Available By Means of These Cutters and Accessories

5/16" Cutters—Sizes and Shapes

No.	Diam.	Width	Radius
D-1	.950	.177	.125
D-2	.950	.264	.187
D-3	.950	.354	.250
D-4	.950	.442	.312
D-20	.994	.221	.125
D-21	1.03	.442	.250
D-40	1.09	.303	.093
D-41	1.16	.388	.125
D-60	.950	.125	
D-61	.950	.156	
D-62	.950	.187	
D-63	.950	.250	
D-80	1.25	.442	1/8 - R

No.	Diam.	Width	Radius
D-10	1.02	.177	.125
D-11	1.06	.264	.187
D-12	1.09	.354	.250
D-13	1.13	.442	.312
D-30	1.18	.282	.125
D-31	1.24	.344	.156
D-50	1.13	.194	.093
D-51	1.20	.260	.125
D-70	1.12	.177	
D-71	1.21	.282	

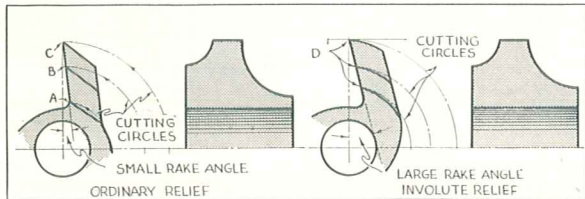

In the ordinary cutter, shown at left, points B and C must be left weak, to get adequate clearance at A. Note the small rake angle in this cutter. Notice how the involute relief of our cutters provides strong cutting edges at D, and the large rake angle which makes the edges cut instead of scrape.

SMALL SHAPER & DRILL PRESS CUTTERS—3-Lip Type

Like the larger 1/2" hole cutters intended for use on the shaper only, these 5/16" hole cutters—designed for use on shaper or drill press, are made of chrome-vanadium steel, which combines toughness with deep-hardening qualities. They are hardened and tempered in oil like all fine tools, so that they will not only stand up in service, but so that they can be re-sharpened without loss of cutting qualities. Cutters made of common machine steel may look like these, but they will not stand up, and, since they are merely case-hardened, they cannot be re-sharpened without ruining them.

One of the greatest advantages of our cutter design is the involute relief of the cutting edge, shown in the diagram below. While this re-

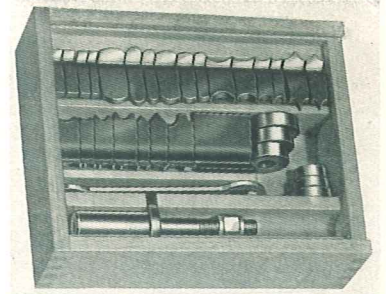

quires special machinery to produce, it is important because it insures adequate clearance at the cutting edge, without at the same time weakening the edge as ordinary straight grinding does. The larger rake angle of our cutters also gives the cut more of a true shearing action, instead of a scraping one.

All Cutters listed above (5/16" hole) Each.....	\$.60
D-69 Blank Cutter, similar to above, 1 1/2" dia., 1" wide. Each	\$.85
No. 978 Adapter for 5/16" hole cutters. Fits No. 974 drill-press spindle. Each	\$.90
Shipping Weight 8 oz. Code Word NESSA.	
No. 979 Set of six depth collars, 5/16" hole.....	\$.75
Shipping Weight 8 oz. Code Word NESDC.	
No. 980 Complete Set of 24 Cutters listed above, (including D-69), 5/16" hole, with No. 978 adapter and No. 979 collars, packed in wood box	\$15.95
Shipping Weight 2 lbs. Code Word NESSC.	

CUTTER HEAD USES MOULDING KNIVES ON PAGE 10, INCREASES SHAPER RANGE

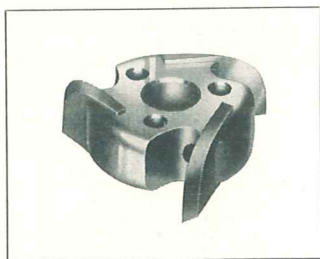

It is now possible for the craftsman who has any of the moulding cutter knives (listed on page 10) for his circular saw to now use these same knives on his shaper. The use of the No. 1343 Safety Cutter Head thereby increases the number of shapes which can be made on the shaper.

Made of steel accurately balanced for precision work this head is not only handy in the home workshop but due to its ruggedness is being used for heavy duty and production work. The three knives are locked into the

head so that they are completely safe in operation. An accessory which permits you to get greater use out of your saw moulding knives.

Important: Do not use any of the saw moulding cutter heads (shown on page 10) on the Shaper!

No. 1343 3-Knife Safety Cutter Head, 3/4" bore with 1/2" bushing, to fit 1/2" and 3/4" spindles. Uses regular moulding cutter knives. With wrench **\$3.95**
Ship. Weight, 1 1/2 lbs. Code Word SHAND.

SAFETY CUTTER HEAD AND SEPARATE BLANK KNIVES FOR SPECIAL MOULDINGS

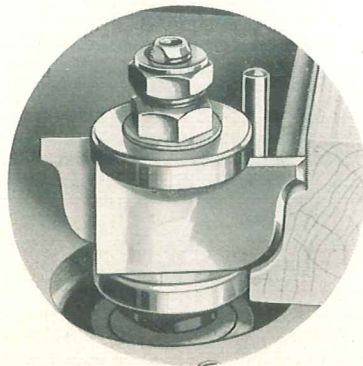

Special mouldings that cannot be made with the standard shaper cutters, special cope cuts—all the work that the experienced shaper operator wants to do can be done with the No. 1192 Cutter Head and blank knives. The head is an innovation. It is accurately machined so as to eliminate vibration; grooves

No. 1192 Safety Cutter Head for blank beveled knives, with tightening block, but no knives. For 1/2" spindle only. Ship. Wt. 1 1/2 lbs. Code Word SHAPB.	\$3.95
No. 1193 1/2" wide blank knives, set of two. Code SHAPC.....	2.30
No. 1194 3/4" wide blank knives, set of two. Code SHAPD.....	2.30
No. 1195 1" wide blank knives, set of two. Code SHAPE.....	2.30
No. 1196 1 1/2" wide blank knives, set of two. Code SHAPF.....	3.00
Average shipping weight per set 6 oz.	

are carefully milled to close tolerances to insure both knives being clamped with the same pressure and a spherical equalizing washer is used under the head. When a setup has been made it can be kept for future use, as the whole head may be removed from the machine. Head is bored for 1/2" spindle only.

Blank knives are 2 1/2" long, self-hardening and sandblasted so that cutter design may be drawn directly on them.

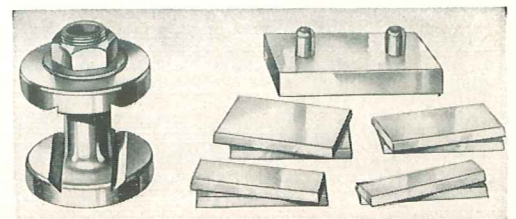

PULLEYS, BELTS, Line Shaft Equipment and LAMP ATTACHMENT

Find Many Uses In the Craftsman's Home Workshop!

Pulleys for V-Belts

Type "A" Belts

Our V-Pulleys are designed for belts measuring $\frac{1}{2}$ " wide, $\frac{3}{8}$ " thick and angle of 38°. The width, angle and general shape are all scientifically designed, and the result of many years' experience with V-Belt Drives. All are of the Safety Disk Type—no spokes—and can be had with $\frac{1}{2}$ ", $\frac{5}{8}$ " or $\frac{3}{4}$ " bores. $\frac{5}{8}$ " and $\frac{3}{4}$ " bores have $\frac{1}{8}$ " keyway.

All have $\frac{5}{16}$ " hollow-head set-screw. These are not ordinary stamped pulleys. They run true and are balanced perfectly. $\frac{1}{2}$ " bore furnished unless otherwise specified.

Cat. No.	Out-side Diam.	Code Word	Price Each
5200	2"	PULOA	.35
5225	2 $\frac{1}{4}$ "	PULOB	.40
5250	2 $\frac{1}{2}$ "	PULOC	.45
5275	2 $\frac{3}{4}$ "	PULOD	.45
5300	3"	PULOE	.50
5350	3 $\frac{1}{2}$ "	PULOF	.55
5400	4"	PULOG	.55
5450	4 $\frac{1}{2}$ "	PULOQ	.65
5500	5"	PULOH	.75
5550	5 $\frac{1}{2}$ "	PULOP	.85
5600	6"	PULOJ	.90
5650	6 $\frac{1}{2}$ "	PULOQ	1.10
5700	7"	PULOL	1.20
5800	8"	PULOK	1.50
6100	10"	PULOM	2.00
6200	12"	PULON	2.75

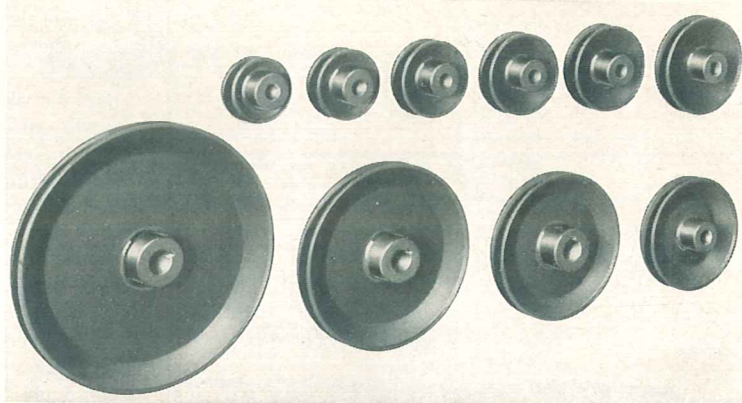

Please note that Nos. 6100 and 6200 V-pulleys can be furnished in $\frac{3}{4}$ " bore only. All other sizes can be furnished in $\frac{1}{2}$ ", $\frac{5}{8}$ " and $\frac{3}{4}$ " bores. For boring to other sizes, up to 1" add 25c to catalog price. Maximum bore available on Nos. 5200 to 5300 is $\frac{3}{4}$ ".

Cone Pulleys for V-Belts

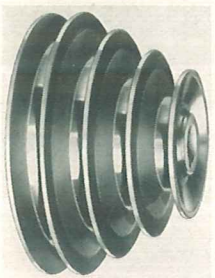

Made for the same size V-belt as plain pulleys listed above, these cone pulleys are useful for a wide variety of drives. Pulleys may be used in pairs as listed in table below and will provide the speeds listed in the third column when used with 1725 r.p.m. motor.

All cone pulleys available in $\frac{1}{2}$ ", $\frac{5}{8}$ " and $\frac{3}{4}$ " bores. $\frac{1}{2}$ " furnished unless otherwise ordered.

Driver	Driven	Speeds with 1725 r.p.m. motor			
718	718	900	1500	2200	3450
720	720	1200	1545	1980	2575
718	720	650	1000	1300	1725
720	718	1725	2400	3400	5000
932	932	900	1400	2200	3400
985	985	590	1275	2450	5000

- No. 718 Four-step cone pulley (small).....each \$.75
Shipping Weight 1 $\frac{1}{4}$ lbs. Code Word CONPA.
- No. 720 Four-step cone pulley (large).....each 1.10
Shipping Weight 1 $\frac{3}{4}$ lbs. Code Word CONPB.
- No. 932 Four-speed cone pulleyeach 1.25
Shipping Weight 2 $\frac{1}{2}$ lbs. Code Word DUBLC.
- No. 985 Four-speed cone pulleyeach 1.30
Shipping Weight 2 $\frac{1}{2}$ lbs. Code Word NEWPU.

V-Belts

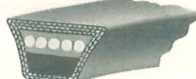

Designed to make complete and perfect contact with the sides of the V-groove, these belts will transmit maximum horsepower with minimum slip. Cords are saturated with pure liquid rubber and imbedded in special rubber stock which resists fatigue and carries off heat.

NOTE: When ordering belts for which number is not known, measure around outside diameters of pulleys, then select belt of nearest outside circumference in the table. Do not use inside circumference.

Cat. No.	Outside Circumference	Inside Circumference	Width	Thickness	Angle	Code Word	Price Each
284	30 $\frac{1}{16}$ "	29 $\frac{3}{16}$ "	$\frac{1}{2}$ "	$\frac{3}{32}$ "	38°	BELTA	.75
**331	35 $\frac{1}{8}$ "	33 $\frac{3}{8}$ "	$\frac{1}{2}$ "	$\frac{3}{32}$ "	38°	MULTG	.80
340	35 $\frac{3}{8}$ "	35"	$\frac{1}{2}$ "	$\frac{3}{32}$ "	38°	BELUX	.80
355	38 $\frac{1}{8}$ "	37"	$\frac{1}{2}$ "	$\frac{3}{32}$ "	38°	FORVB	.80
387	40 $\frac{1}{8}$ "	38 $\frac{3}{4}$ "	$\frac{1}{2}$ "	$\frac{3}{32}$ "	38°	FORDP	.85
410	41 $\frac{1}{8}$ "	41"	$\frac{1}{2}$ "	$\frac{3}{32}$ "	38°	BELTB	.85
430	44"	42 $\frac{1}{2}$ "	$\frac{1}{2}$ "	$\frac{3}{32}$ "	38°	FORSL	.90
453	47 $\frac{3}{8}$ "	45 $\frac{3}{8}$ "	$\frac{1}{2}$ "	$\frac{3}{32}$ "	38°	MORBL	.90
501	51 $\frac{5}{8}$ "	51 $\frac{1}{4}$ "	$\frac{1}{2}$ "	$\frac{3}{32}$ "	38°	MORUV	1.00
510	52 $\frac{1}{8}$ "	51 $\frac{5}{8}$ "	$\frac{1}{2}$ "	$\frac{3}{32}$ "	38°	JOIVB	1.00
520	54 $\frac{1}{4}$ "	52 $\frac{5}{8}$ "	$\frac{1}{2}$ "	$\frac{3}{32}$ "	38°	BELTC	1.00
530	55"	53 $\frac{3}{8}$ "	$\frac{1}{2}$ "	$\frac{3}{32}$ "	38°	BELTD	1.00
560	58 $\frac{3}{8}$ "	57 $\frac{1}{8}$ "	$\frac{1}{2}$ "	$\frac{3}{32}$ "	38°	EICVB	1.00
568	59 $\frac{1}{4}$ "	58 $\frac{5}{8}$ "	$\frac{1}{2}$ "	$\frac{3}{32}$ "	38°	FORVD	1.00
583	60 $\frac{3}{4}$ "	59 $\frac{5}{8}$ "	$\frac{1}{2}$ "	$\frac{3}{32}$ "	38°	FORBL	1.10
588	61 $\frac{5}{8}$ "	60 $\frac{1}{2}$ "	$\frac{1}{2}$ "	$\frac{3}{32}$ "	38°	FORVC	1.10
595	61 $\frac{3}{4}$ "	60 $\frac{3}{4}$ "	$\frac{1}{2}$ "	$\frac{3}{32}$ "	38°	BABEL	1.25
618	64 $\frac{7}{8}$ "	63 $\frac{1}{4}$ "	$\frac{1}{2}$ "	$\frac{3}{32}$ "	38°	BELTL	1.25
644	66 $\frac{3}{8}$ "	64 $\frac{1}{2}$ "	$\frac{1}{2}$ "	$\frac{3}{32}$ "	38°	BELTF	1.25
670	69 $\frac{1}{2}$ "	67 $\frac{7}{8}$ "	$\frac{1}{2}$ "	$\frac{3}{32}$ "	38°	BELTU	1.30
*673	74 $\frac{1}{8}$ "	73 $\frac{1}{2}$ "	$\frac{1}{2}$ "	$\frac{3}{32}$ "	38°	PREBL	1.00
750	76 $\frac{3}{4}$ "	76 $\frac{1}{4}$ "	$\frac{1}{2}$ "	$\frac{3}{32}$ "	38°	JOBAS	1.85

* This belt $\frac{1}{8}$ " wide, for No. 620 drill press.
** Special belt for variable-speed scroll-saw.

MANY USES for Versatile Lamp Attachment

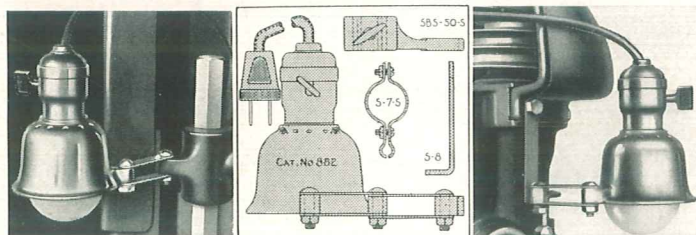

To bring light to your work just where it is needed, in volume enough for accuracy in following layouts, yet not bright enough to glare, there is nothing quite the equal of the No. 882 lamp attachment. Swung on the built-in brackets on drill press, band saw, scroll saw or other machine, it brings the light just where it is needed, yet can be swung out of the way at touch of the finger. It furnishes every machine with its own individual illumination, and makes it independent of the shop lighting system.

It can be used as a workbench light, and provided with additional links to place it wherever wanted over a wide bench. It can be used as a sewing-machine light, as an illuminant for laboratory instruments and other purposes. Uses 15 or 25 W. Bulbs.

- No. 882 Lamp attachment, with shade, socket and cord, four flat links, three bolts, spacer and attachment bracket Shipping Weight 1 $\frac{1}{2}$ lbs. Code Word LAMPA. **\$1.60**
- S-3-S Extra support links, with spacer, screw and nut, per pair **.15**
- S-7-S Lamp Attachment Bracket for 700 scroll saw, each.. **20**
- S-8 Lamp Attachment Clamp for 970 drill press, each.... **.15**
- SBS-50-S Lamp Attachment Bracket for 785 and 385 band saws, each **.35**

Speed Table

This table will enable you to select the proper pulleys for the approximate speeds listed. Machine pulley speeds are based on a motor speed of 1725 R.P.M.

Mot. Pulley Size, In.	Pulley on Machine: Size, In.												
	2	2 $\frac{1}{4}$	2 $\frac{1}{2}$	2 $\frac{3}{4}$	3	3 $\frac{1}{2}$	4	5	6	7	8	10	12
2	1725	1498	1325	1187	1075	905	781	614	505	425	371	295	245
2 $\frac{1}{4}$	1828	1725	1525	1360	1235	1040	897	684	577	490	426	327	282
2 $\frac{1}{2}$	2120	1875	1725	1542	1402	1180	1019	794	655	556	483	372	319
2 $\frac{3}{4}$	2330	2120	1880	1725	1562	1317	1148	887	732	624	542	416	356
3	2550	2260	2040	1860	1725	1452	1252	980	807	685	596	458	392
3 $\frac{1}{2}$	2990	2650	2380	2165	1985	1725	1489	1162	958	815	708	543	466
4	3800	3300	2920	2605	2360	2000	1725	1345	1100	940	820	650	540
5	4875	4230	3750	3350	3040	2560	2205	1725	1425	1210	1050	835	695
6	5900	5140	4550	4060	3700	3105	2680	2095	1725	1480	1250	1010	840
7	6950	6050	5340	4775	4350	3650	3160	2460	2025	1725	1500	1190	990
8	8000	6950	6150	5490	5000	4200	3600	2825	2320	1985	1725	1350	1135
10	10000	8750	7750	6920	6300	5300	4575	3560	2940	2500	2160	1725	1430
12	12000	10500	9350	8350	7560	6400	5500	4300	3540	3020	2620	2080	1725

LINE SHAFT EQUIPMENT

Shaft Hangers

Self-aligning in every direction. Adjustable up and down from 4" to 5". Large oil wells. For $\frac{3}{4}$ " shaft only.

No. 370 Line Shaft Hanger \$2.50
Shipping Weight 6 lbs. Code LIHAN

Flexible Shaft Couplings

Used to connect motor direct to end of line shaft. One side bored $\frac{3}{4}$ "; other, $\frac{1}{2}$ ", $\frac{5}{8}$ " or $\frac{3}{4}$ ". Specify size desired.

No. 379 Flexible Coupling \$1.10
Shipping Wt. 1 $\frac{1}{2}$ lbs. Code LICOP.

$\frac{3}{4}$ " Shaft Collars

Steel collars with $\frac{3}{4}$ " bore. Have $\frac{1}{8}$ " x $\frac{1}{8}$ " hollow set screws. Used to keep shaft in proper position lengthwise.

No. 374 $\frac{3}{4}$ " Shaft Collar..\$0.30
Shipping Weight 4 oz. Code LICAL.

$\frac{3}{4}$ " Line Shafting

Ground and polished to precision limits. Carried in 1', 2', 3', 4', 5', 6', 8' and 10' lengths. Above-the-average shafting.

No. 372 $\frac{3}{4}$ " Shafting, ft. \$0.35
Ship. Wt. 2 $\frac{1}{2}$ lbs. per ft. Code LISHA

WHAT DO YOU WANT IN YOUR SCROLL SAW?

Here Are Some Of The Reasons Why Our Modern High-Speed Scroll Saw Gives You

BETTER PERFORMANCE — LONGER LIFE — FASTER OUTPUT

Experienced scroll-saw users know that there are several features essential in a scroll saw. It must be capable of using all types of blades efficiently. It must operate with minimum blade breakage. It must operate with minimum vibration at all speeds,

and it must have a selection of speeds to suit various types of work. Only by purchasing a machine that offers ALL these features can you obtain full satisfaction. When selecting your scroll saw, ask yourself these questions:

A Wide Range of Speeds—or Only One or Two?

Some scroll saws can be operated at only one speed. Some have only two. From our wide experience as the originators of the modern type of high-speed scroll saw, we know that it is not possible to get proper efficiency in cutting a wide range of materials, using a wide variety of blades, with only one or two speeds. If only one or two speeds are available, they must be a compromise between the correct speed for fine, delicate work and the correct speed for heavy work. And compromises are not good enough.

In our scroll saw, you can have your choice of either four well-selected speeds, suitable for a wide variety of work, or a drive that gives you ANY speed from 650 to 1700 r.p.m. You can select the speed you need; not a speed that "will have to do."

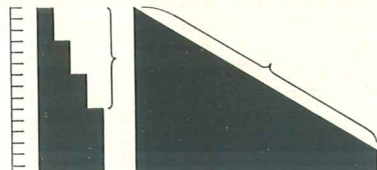

With our scroll saws, you may choose either four well-selected speeds or an infinitely variable range of speeds that will enable you to cut any material with maximum efficiency.

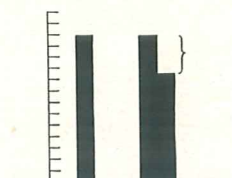

Some scroll saws offer you only one speed. Some have only two speeds of very limited range.



Many scroll-saw guides are elementary in design and suitable for only one blade. Others, which accommodate more blades, are clumsy and awkward to adjust.

Others, while more effective than the first two, can take only a few sizes of blades with proper efficiency and are not completely adjustable.

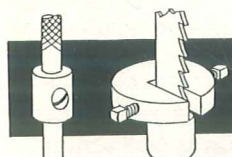

Many scroll saw chucks will not take saber blades or round-shank files. To hold these you must have extra chucks.

Elementary, Limited Guides—or Guides that Are Efficiently Adjustable?

Some scroll saws are furnished with a guide that we regard as suitable only for one size of blade. Some are equipped with guides that are awkward to adjust and hard on blades. Some have roller guides which will take only a few sizes of blades efficiently.

Our patented Universal guides are the only guides we know of which will take all commercial sizes of blades and guide them properly and efficiently. This because the principle is entirely different from any other. You select a slot in the hardened-steel disk which is of the correct width for the blade—set it easily and quickly to the bottom of the blade teeth, (NOT to the bottom of the slot) then set the roller support to back it up. That is all there is to it—but the blade is guided properly and efficiently, as it can be in no other way. And the roller support is especially designed for high-speed reversing, so that it actually rolls, and does not drag on the blade.

You can use any blade in this guide, from the heaviest saber blade we list to the finest marquetry blade and adjust the guide to get the best work out of the blade.

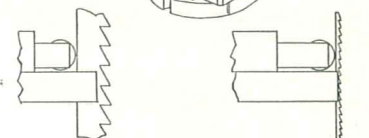

Our Universal blade guide can quickly and easily be set to take any scroll-saw blade, set to exactly the correct tooth depth and properly supported by a high-speed roller.

Chucks that Require "Extras"—or Chucks that Are Completely Universal

Many scroll-saw chucks or vises will hold only one type of blade—a jeweler's blade. If you want to use saber blades you must use an extra chuck, first removing the standard one. On many saws, you must use still another extra chuck if you want to use round-shank files or sanding attachments in the machine.

The patented chucks in our machine are completely universal. They will take jewelers' blades, pin blades, saber blades, round-shank files up to 1/4" and any other tool with 1/4" shank—without any "extras". And they hold saber blades in the only efficient manner—between V-jaws gripping the edges of the blades; not the flat.

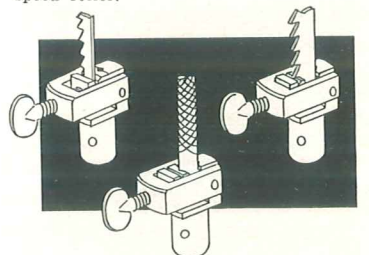

Our patented chucks will hold any type of blade, as well as files and round-shank tools, without extras.

A Machine that Will Bevel-Cut Only Short Lengths—or One that Is Unlimited?

Most scroll saws have tilting tables—but what the prospective purchaser does not always realize is that the ordinary tilting table has one limitation. The table tilts to right or left as you face the machine, which means that if you want to rip or cut a piece of stock at an angle, you can feed the stock through the saw only until it strikes the saw overarm.

On our scroll saw, the table not only tilts normally to right or left, but, if you want to make a long cut on a bevel, you merely rotate the table bracket through 90 degrees, turn the chucks so that the blade cuts sidewise, and go ahead with your cut—because the table now tilts to the front, where there is no limit to the length of stock that can be cut.

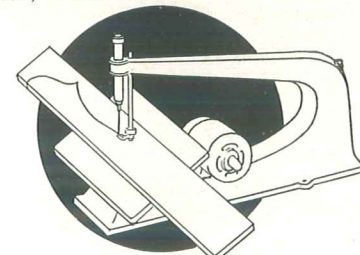

The table on our scroll saw can be rotated and tilted to the front, so that work of any length can be bevel cut when required. Chucks are quickly turned for sidewise cutting.

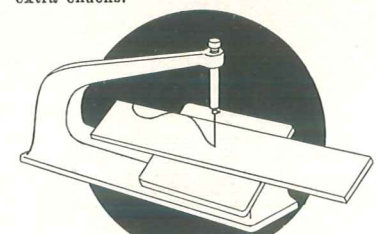

On many scroll saws where the table tilts only to right or left, long work cannot be bevel cut because it will strike the rear of the machine.

Make These Comparisons Yourself

There are many other features in our scroll saws that insure you of longer life, better performance, more convenience and faster output. Our scroll saws are equipped with Timken tapered-roller bearings, automatically lubricated from the splash system in the crankcase. Many other machines that look like ours have only plain bronze bearings. Our scroll saws are equipped with a continuous-flow air pump with intake and outlet valves, built into the crankcase and driven directly from the crankshaft. It is NOT built into the upper plunger, because when this is done, your fine, delicate blades must act as connecting rods to drive the pump, imposing an additional strain on them. In addition, a pump built

into the upper plunger cannot be used for saber-blade work. The spring hold-down on our guide tilts with the table so that it is effective on bevel cuts as well as on straight cuts—a feature missing in many other machines. The upper guide is removed in a flash for inserting blades in pierced work, and is automatically re-set as soon as replaced. The tension adjustment for the blades is fast and simple in action, with no complicated gadgets. . . . and so on. Compare all these things, point by point, with any other machine, and you will realize just why these scroll saws offer you so much more value than any other.

FAST, ACCURATE Work Easy To Do on This 4-Speed Scroll Saw

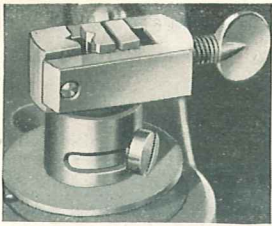

Lower chuck of steel. Light but strong and holding all blades.

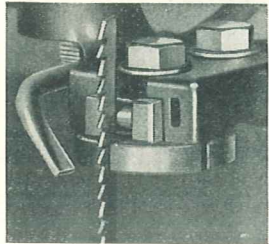

Highly efficient disk blade guide and roller support.

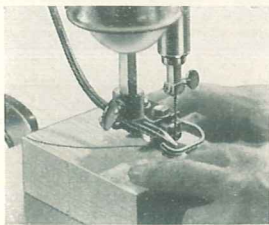

Work up to 1 1/4" thick may be cut on this saw.

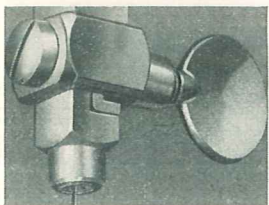

Where very fine blades are used constantly, the self-centering chuck jaw is used.

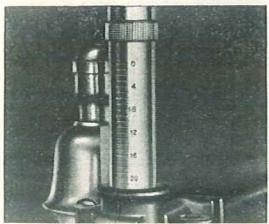

Tension of spring can be adjusted to suit blade, and graduations on tube and adjustment.

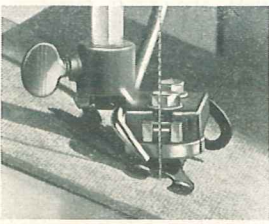

The spring hold-down functions even when the table is tilted; an important feature.

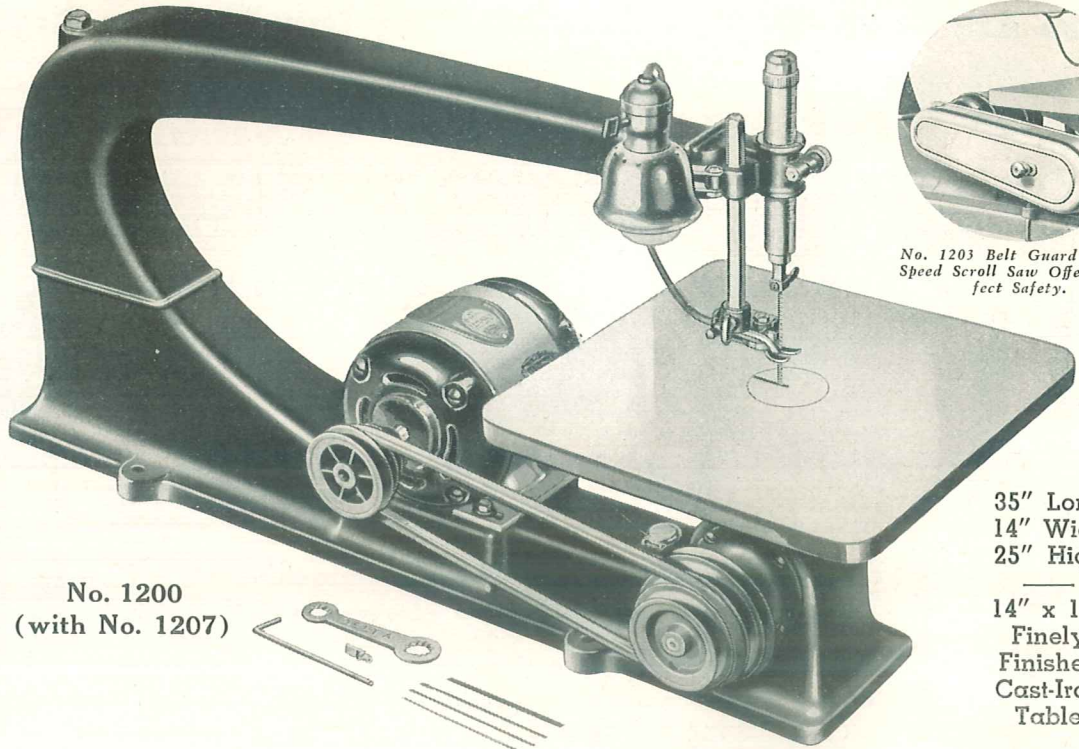

No. 1200 (with No. 1207)

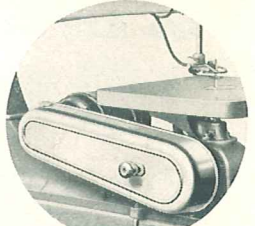

No. 1203 Belt Guard for 4-Speed Scroll Saw Offers Perfect Safety.

35" Long
14" Wide
25" High

14" x 14" Finely Finished Cast-Iron Table

Timken-bearing crankshaft . . shaft-driven blower pump which makes air available even for saber blades . . universal tilting table tilting for sidewise cutting as well as for straight cuts . . the finest completely universal blade guide made . . high-speed blade support . . adjustable blade tension . . splash-lubricated drive . . tilting spring hold-down . . these are only a few of the things that make our 24" scroll saws the finest tools of their type ever offered to the craftsman.

From the moment of its introduction, this was acknowledged by engineers, craftsmen and mechanics to be the finest scroll saw they had ever seen. Examine it for yourself; compare it with any other scroll saw—at any price—and you will see why these experts have called it "The Finest Scroll Saw Ever Made".

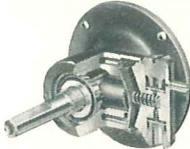

Above: Section through pump. Right: No. 1207 accessory group.

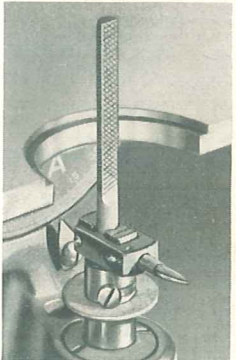

Files, also, are held in the V-jaws of the lower chuck.

No. 1200	24" 4-Speed Scroll Saw, with one saber blade, 3 jewelers' blades, four speed cone pulley on arbor, puzzle-blade jaw and light attachment. Without motor, motor pulley or belt	\$29.90
	Shipping Weight 117 lbs. Code Word LUXSA.	
No. 1207	Standard accessory group for 4-Speed Scroll Saw, consisting of:	
No. 718	Cone pulley for motor, 1/2" bore; provides speeds of 650, 1000, 1300 and 1750 r.p.m.	\$.75
	Shipping Weight 18 oz. Code Word CONPA.	
No. 340	V-belt (13" cent. to cent.)	\$.80
	Shipping Weight 8 oz. Code Word BELUX.	
	Price of No. 1207 group complete.	\$ 1.55
	Shipping Weight 1 1/4 lbs. Code Word LUXAC.	
No. 716	Steel Stand (Top 7"x33"; 31 1/2" high)	\$ 8.25
	Shipping Weight 50 lbs. Code Word LASAS.	
No. 1206	4-Speed Scroll Saw Unit, consisting of No. 1200 Scroll Saw, No. 1207 accessory group, No. 716 steel stand with hook bolts. Without motor or belt guard.	\$39.70
	Shipping Weight 170 lbs. Code Word LUXUN.	
No. 1203	Belt and pulley guard for No. 1200 4-speed Scroll Saw	\$ 6.85
	Shipping Weight 7 lbs. Code Word LUXBG.	

For either of these models, use Motor No. 6300 or 6000, or No. 6600 for three phase installation. See pages 28 to 30 for Motors.

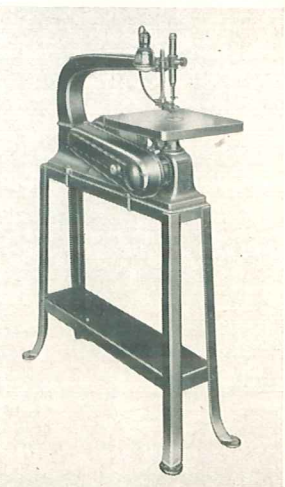

No. 1206 4-Speed Scroll Saw unit. A similar Multi-Speed unit is available.

A THOUSAND SPEEDS At The Touch of Your Finger With This New De-Luxe Multi-Speed Scroll Saw!

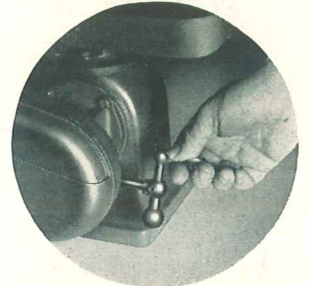
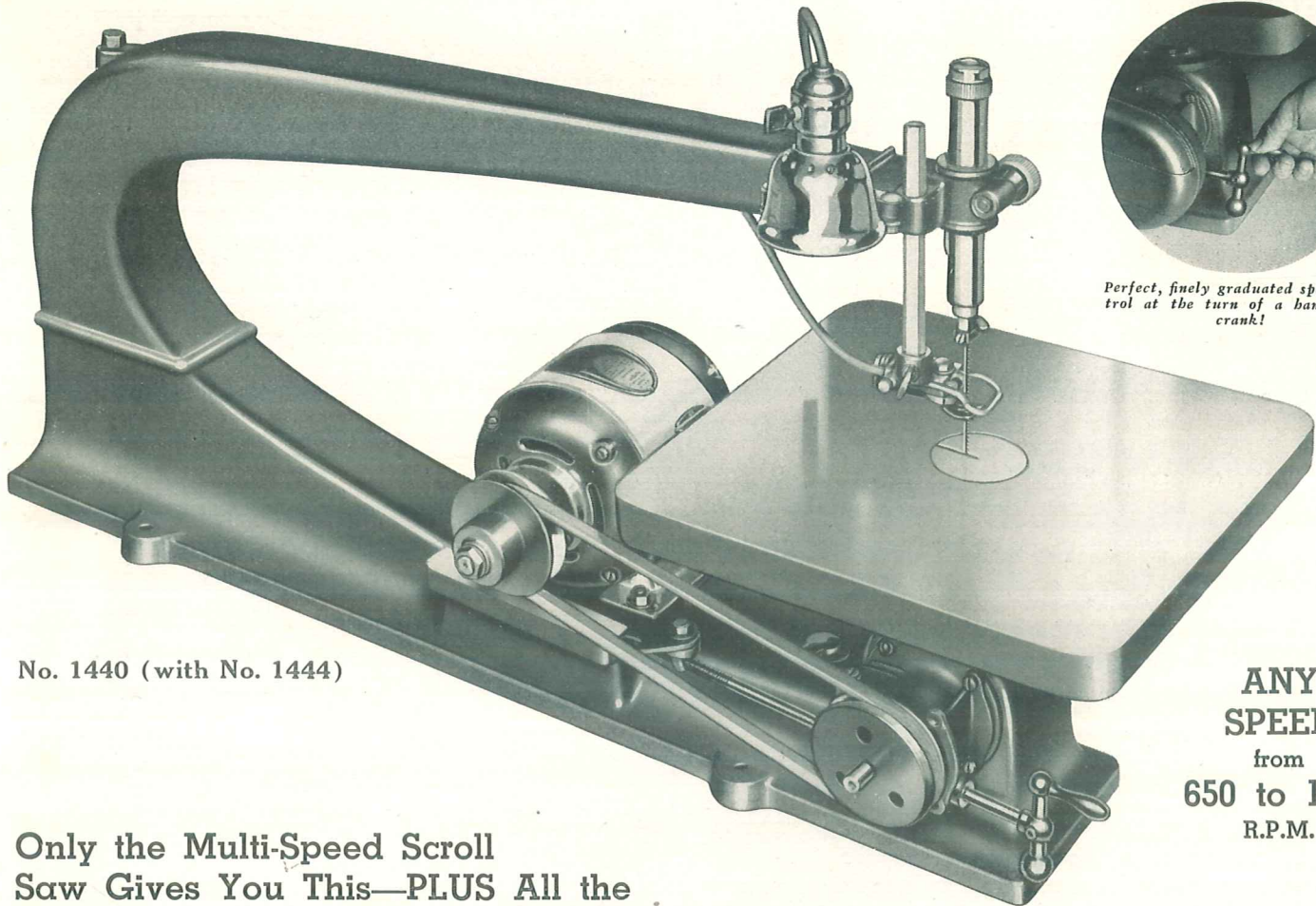

Perfect, finely graduated speed control at the turn of a handy ball crank!

No. 1440 (with No. 1444)

**ANY
SPEED**
from
650 to 1700
R.P.M.

Only the Multi-Speed Scroll Saw Gives You This—PLUS All the Advantages of the **Original High-Speed Scroll Saw!**

Now—for the first time—you can have all the advantages of the modern high-speed scroll saw made by the makers of the original high-speed, high-capacity 24"

scroll saw, together with perfected control of speed! Here are combined in one machine all the points that have made our scroll saws the best of their kind—PLUS modern, up-to-the-minute efficiency in speed selection!

Here Is Why You Need These Speeds

A two-speed scroll saw not only fails to give you fast enough speeds for fast, fine cutting, and speeds low enough for many jobs, but also has a very limited speed range. A four-speed scroll saw, while the range of speeds is wider, does not enable the most efficient speed to be selected for many materials. With the new Multi-Speed Scroll Saw, you can select ANY speed from 650 to 1700 r.p.m. controlling the speed within 1 or 2 r.p.m. if necessary. High speed for fast, fine work—low speed for heavy work—and ANY speed in between!

Note: No. 6000 (old No. 1100) motor recommended for this saw.

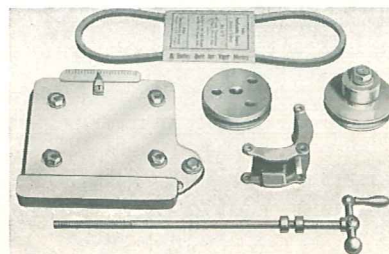

No. 1444 Standard accessory group for Multi-Speed Scroll Saw model.

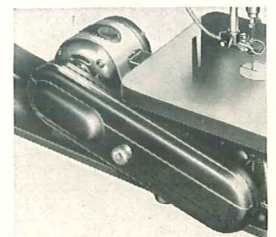

No. 1442 belt-pulley guard for Multi-Speed Scroll Saw.

No. 1440 "Multi-Speed" Scroll Saw, with one saber blade, 3 jewelers' blades, puzzle jaw for upper chuck and light attachment. Without arbor pulley. **\$28.80**
Without motor, motor pulley, belt or belt guard.
Shipping Weight 116 lbs. Code Word MULTA.

No. 1444 Standard accessory group for making a Multi-Speed Scroll Saw, consisting of:

No. 1446 Variable-speed motor pulley, pulley only. **3.75**
 $\frac{1}{2}$ " bore
Shipping Weight 2 lbs. Code Word MULTH.

No. 1447 Motor base, with bracket, screw and handle. **3.50**
Shipping Weight 10 lbs. Code Word MULTI.

No. 331 Special V-belt for variable-speed pulleys only. **.80**
Shipping Weight 8 oz. Code Word MULTG.





No. 1443 Special arbor pulley for scroll saw, $\frac{1}{2}$ " bore. **1.00**
Shipping Weight 1 lb. Code Word MULTD.



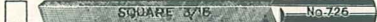

Price of No. 1444 group complete. **\$9.05**
Shipping Weight 14 lbs. Code Word MULTE.

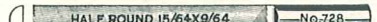
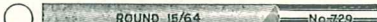
No. 1445 24" Multi-Speed Scroll Saw Unit, consisting of No. 1440 Scroll Saw, No. 1444 accessory group and No. 716 steel stand with hook bolts. Without motor or belt guard. **\$46.10**
Shipping Weight 182 lbs. Code Word MULTF.

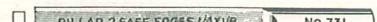
No. 1442 Belt and pulley guard for No. 1440 Scroll Saw only. **\$ 5.90**
Shipping Weight 7 lbs. Code Word MULTC.

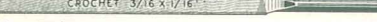
MACHINE FILES FOR SCROLL SAWS

-  **No. 726** (Square). 1/4" Shank. Code FILEA. Each **.60**
-  **No. 727** (Crochet). 1/4" Shank. Code FILEB. Each **.60**
-  **No. 728** (1/2 Rd.). 1/4" Shank. Code FILEC. Each **.60**
-  **No. 729** (Round). 1/4" Shank. Code FILED. Each **.60**
-  **No. 730** (3-Sq.). 1/4" Shank. Code FILEE. Each **.60**
-  **No. 731** (Pillar). 1/4" Shank. Code FILEF. Each **.60**
Approximate Shipping Weight 4 oz.
- No. 740** Set of the above 6 Files, 1/4" Shank **\$3.30**
Shipping Weight 8 oz. Code Word FILEX.

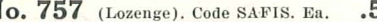
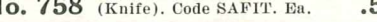
-  **No. 751** (1/8" Sq.). Code SAFIL. Ea. **.50**
-  **No. 752** (Crochet). Code SAFIM. Ea. **.50**
-  **No. 753** (1/2 Round). Code SAFIN. Ea. **.50**
-  **No. 754** (Round). Code SAFIO. Ea. **.50**
-  **No. 755** (3-Square). Code SAFIP. Ea. **.50**
-  **No. 756** (Pillar). Code SAFIR. Ea. **.50**
-  **No. 757** (Lozenge). Code SAFIS. Ea. **.50**
-  **No. 758** (Knife). Code SAFIT. Ea. **.50**
Approximate Shipping Weight 3 oz.
- No. 760** Set of the above 8 1/8" Shank Files **\$3.65**
Shipping Weight 6 oz. Code Word SAFIV.

SABER BLADES FOR WOOD

Close to 80 per cent of all scroll saw work, except the finer work in wood and metal, can be done with saber blades, due to the fact that the free end is properly backed up and supported close to the point where the cutting strain takes place. Made of the best steel, accurately hardened and set. These blades are 4 1/2" long over all.

No. of Blade	Thickness & Width	Teeth per in.	Code Word	Price Per 1/2 Doz.
No. 703	.025" x .187"	9	SABLA	\$0.75
No. 704	.035" x .250"	7	SABLB	.75

Ship. Wt. per pkg. of six approximately 5 oz.

INDIVIDUAL GUIDES

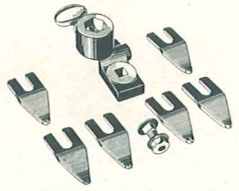

These guides supplement the regular guide and hold-down, and are used where close following of a line or pattern is important. Ideal for puzzle and marquetry work. Sets consist of six hardened-steel guides and bracket. No. 712 fits No. 700 scroll saw. No. 1202 fits No. 1200 and 1440 scroll saws.

- No. 712** Set of 6 guides, with blower-nozzle bracket. **\$1.35**
Shipping Weight 15 oz. Code Word SAGID.
- No. 1202** Set of 6 guides and bracket **1.55**
Shipping Weight 18 oz. Code Word LUXGA.

SELF-CENTERING CHUCK

Fits lower plunger of all our scroll saws. A boon to craftsmen who specialize in puzzle and marquetry work. Fine blades are automatically guided to center of chuck and locked securely with thumb screw, saving much time on interior cuts.

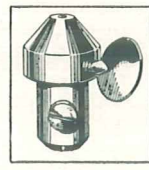

- No. 715** Self-centering lower jaw for No. 700, 1200 and 1440 scroll saws **\$0.75**
Shipping Weight 5 oz. Code Word LACHU.

LOWER SABER BLADE GUIDE

Supports saber blade directly beneath table. Enables perfect straight-line work to be done, when used in conjunction with the upper guide, as blade is supported above and below table.

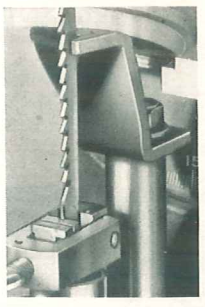

- No. 1204** The Lower Guide for No. 1200 and 1440 scroll saws, with post, nut and thumb-screw **\$0.85**
Shipping Weight 10 oz. Code Word LUXLS.

SANDING ATTACHMENT IS UNIQUE

Built to sand both concave, convex or flat surfaces, this attachment saves hours of hand labor. It does away with the annoyance of makeshift devices using pieces of sandpaper. Knurled knob expands body of attachment, and tightens garnet sleeve securely. 1 1/8" wide, 1/2" thick and 2 1/2" long on body. Shank 1/2" diameter, fits lower chuck on No. 700, 1200 and 1440 scroll saws.

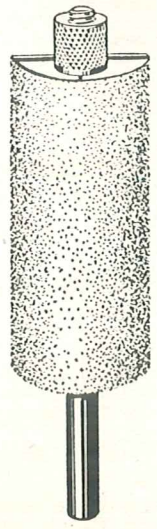

- No. 711** Sanding Attachment fits 24" Scroll Saw with 1 Sleeve **\$1.35**
Shipping Weight 8 oz. Code Word SANAT.
- No. 841** Extra Garnet paper sleeves (medium). Code word SASLK. 1/2 doz. **.60**
Shipping Weight 6 oz. approx.
- No. 842** Extra Garnet Paper Sleeves (Fine) Code word SASLM. 1/2 doz. **.60**
Shipping Weight 8 oz. approx.

New Scroll-Saw Blades For All Types of Material

It has always been a problem to be sure that you were buying the right type of saw blade for the material you wanted to saw. Now, with this new complete listing you will find just the type of blade you want.

These blades are the finest obtainable, 5" long with accurately spaced teeth—properly set and hardened. Ends of blade have 5/16" blank for fastening into chuck. The number in parenthesis following the catalog number is the number of the old similar blade. Gross price applies only to lots of 1 gross or more of one kind of blade.

Size, Inches	No. Teeth	Code Word	Per Doz.	Per Gross
Fret saw blades with wide spaced teeth (not set—not tempered for metal) for sawing wood where extremely thin cut is required—very fast cutting.				
No. 81	.010x.070	14	BLACA	\$.55 \$ 3.75
No. 82	.010x.055	16	BLACB	.55 3.75
No. 83 (10035-211)	.010x.045	18	BLACC	.55 3.75
No. 84 (70028-211)	.008x.035	20	BLACD	.40 3.00
Fret saw blades, wide spaced teeth approx. .010" thicker than above blades (not set). Tempered for sawing plastics, bone, celluloid, etc. Very fast in wood.				
No. 85 (20072-151)	.020x.055	15	BLACE	.55 3.75
No. 86 (20085-121)	.020x.065	12	BLACF	.55 3.75
No. 87	.020x.070	7	BLACG	.70 5.00
No. 88	.020x.110	7	BLACH	.70 5.00
Jig saw blades, filed and set teeth, oil hardened and of medium temper for sawing wood and other substances—will also saw soft metals.				
No. 91 (20125-151)	.020x.110	15	BLACI	.50 3.45
No. 92 (20125-101)	.020x.110	10	BLACJ	.50 3.45
No. 93 (28187-101)	.028x.187	10	BLACK	.70 5.00
No. 94 (28250-71)	.028x.250	7	BLACL	.85 6.00
Piercing saw blade (not set) hardened and tempered for scroll sawing metals, bone, pearl, etc. Used most extensively in fine metal arts. Will discolor wood at high speed because teeth are not set.				
No. 95 (16054-301)	.016x.054	30	BLACM	.55 3.75
No. 96 (16054-211)	.016x.054	20	BLACN	.55 3.75
No. 97 (20125-151)	.020x.070	15	BLACO	.50 3.45
No. 98 (20085-121)	.020x.085	12	BLACP	.55 3.75
Scroll saw blades with set teeth hardened and tempered for sawing metals. Used extensively for sawing templates, light and heavy metal craft, electrolyte metals, etc. Nos. 59, 60, and 61 also good wood cutters.				
No. 58	.020x.070	32	BLACQ	.70 5.00
No. 59	.020x.070	20	BLACR	.70 5.00
No. 60 (20072-151)	.020x.070	15	BLACS	.55 3.75
No. 61 (20085-121)	.020x.085	15	BLACT	.55 3.75
No. 64 (20125-201)	.020x.110	20	BLACU	.70 5.00
No. 65 (28250-201)	.028x.025	20	BLACV	1.70 12.00

THOROUGHLY ENGINEERED 12-Inch Disc Sander Produces High Grade Work

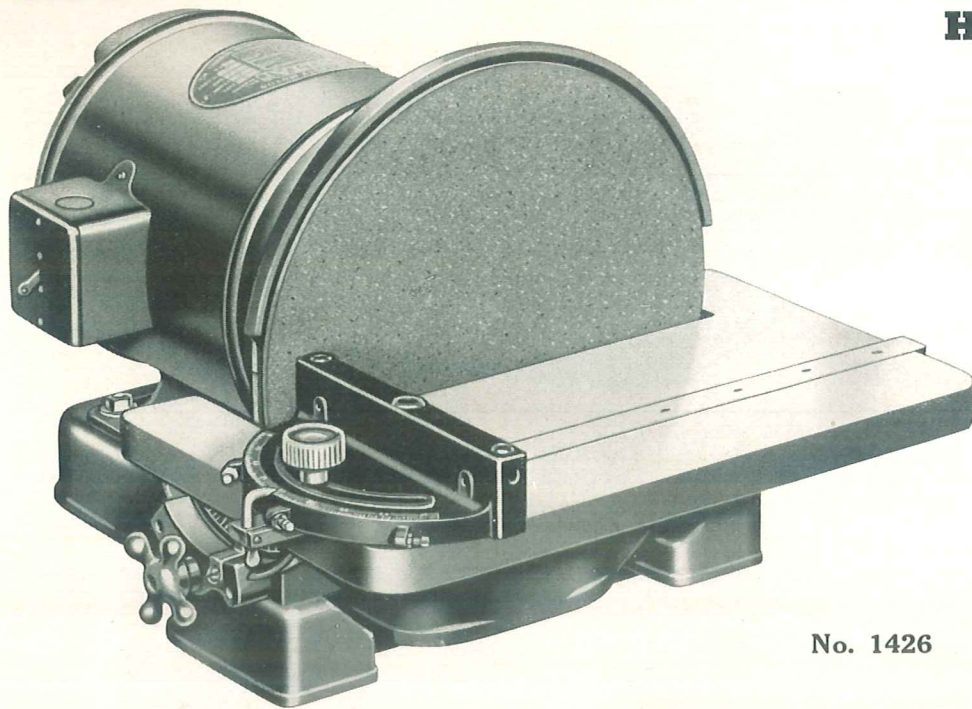

No. 1426

Designed to meet every requirement for accurate sanding, this new Disk Sander is not just another sander, but a high-grade machine tool for equally high-grade work. From its completely machined, true-running 12" disk to its large-surface table and its husky spindle, carried on self-sealed ball bearings, it is designed for long life, low power consumption and accurate, dependable results.

The direct-motor-drive model can be used with any of our ball bearing 1/2-H.P. motors in 8 1/2" frame. The disk in this model fits directly onto the end of the motor shaft, and makes the unit completely self-contained. The belt-drive model makes it possible to use any available motor; to use motors built for odd voltages or frequencies, or to vary the speed to suit individual jobs.

Disk is specially machined to insure proper adhesion of abrasive disks, and the use of "Distic" for applying disks adds the last touch of convenience to the machine. There is no need for messy gluing of disks, no removal of the disk from the machine, no waiting overnight for the new abrasive disk to dry. Abrasive disks can be renewed every few minutes if the operation makes it necessary.

For Finishing, Squaring, Mitering, Fitting, Grinding;

From the pattern shop to the production line in the plant, this machine is adaptable to a very wide variety of operations. In addition to its usefulness for accurate sanding, it can be used for finishing and finishing plastics, bone, celluloid and similar materials; it is used for light grinding and finishing in the metal shop, or for squaring, plain and compound miters, disk and curved-work finishing—for all work where accurate finishing to a line or layout is important.

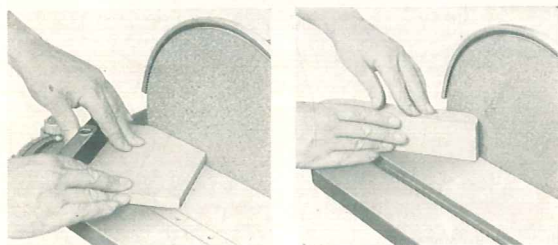

Plain and compound miters are easily sanded with the aid of the miter gage. Accurate work to layout lines accomplished with ease on this precision machine.

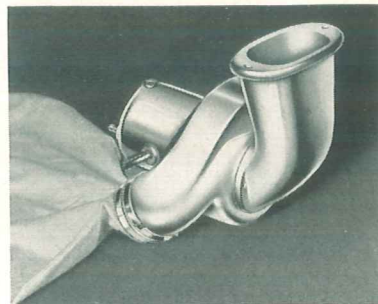

SAWDUST BLOWER Is Practical, Efficient

Owing to the efficient design of the housing in this sander, an exhaust blower for sawdust removal is really practical. No. 1429 blower applied to this sander makes it completely portable, independent of the

shop blower system, and removes one of the drawbacks of the ordinary disk sander. The motor of this blower is of the universal type and will operate on 110 volts A. C. or D. C. Supplied only for 110-volt current.

Condensed Specifications

Overall dimensions: motor-drive model, 16 1/4" wide, 13 1/2" high, 22 3/4" front to rear. Belt-drive model, 16 1/4" wide, 13 1/2" high, 17" front to rear.

Table 9 3/4" x 16 1/4". Polished surface, with 3/8" x 3/4" slot for No. 864 miter gage.

Table tilts 45 degrees for front. Carried on rigid, well-designed trunnions, with large, convenient trunnion-lock knobs. Tilt scale on front trunnion,

with adjustable pointer.

12" disk, flat and true running, for accurate work. Specially machined to insure proper adhesion of abrasive disks.

Husky shaft for belt-drive machine carried on self-sealed ball bearings. No lubrication required for life of bearings.

Sawdust blower available, making machine adaptable for locations where usual disk-sander dust is objectionable.

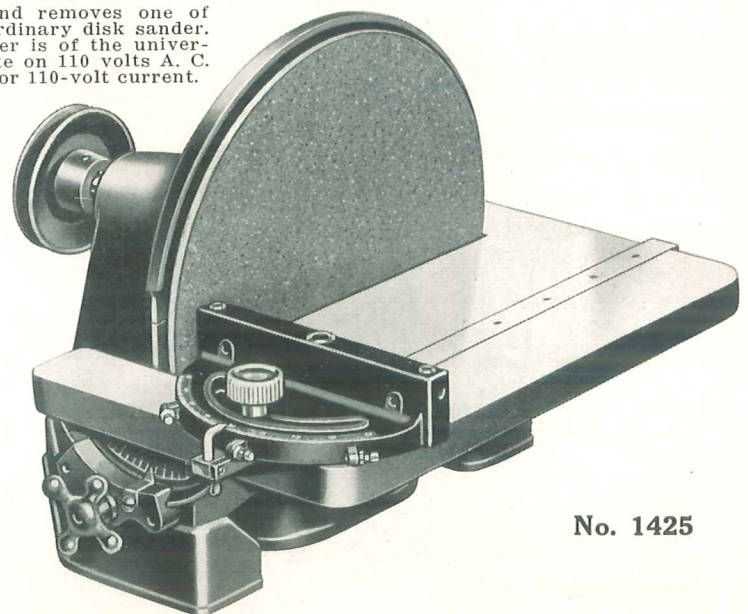

No. 1425

No. 1425	Belt-Drive Disk Sander, with disk, drive shaft and 4" arbor pulley. Without miter gage.....	\$24.85
	Shipping Weight 75 lbs. Code Word DISKO.	
No. 1426	Direct-motor drive Disk Sander, with disk, base and table. Without miter gage or motor.....	18.85
	Shipping Weight 80 lbs. Code Word DISKP.	
No. 1427	12" Garnet disks, medium grit. Packed in cartons of 6. Per package	1.40
	Shipping Weight 3 lbs. Code Word DISKR.	
No. 1428	12" Aluminous-oxide disks for metal, medium grit. Per package of 6	1.60
	Shipping Weight 3 lbs. Code Word DISKS.	
No. 1429	Sawdust blower and adapter for No. 1425 sander. Complete with bag, adapter, switch, cord and plug. For 110 volt, A. C. or D. C. only.....	29.90
	Shipping Weight 15 lbs. Code Word DISKT.	
No. 1432	Steel stand for use with disk sander. Top 12 1/2" x 16 1/2" x 31 1/2" high	\$8.50
	Shipping Weight 40 lbs. Code Word DISKW.	
	(Use No. 583 V-belt for No. 1425 sander. No. 1334 switch rod)	
No. 149	"Distic" for applying disks, per stick.....	.70
	Shipping Weight 1 lb. Code Word DISiC.	

No. 1433	Belt driven unit consisting of: 1425 sander, 1432 stand, 583 belt and 5450 3/4" pulley, without motor or switch rod or miter gage. Ship. Wt. 120 lbs. Code Word DISKV....	\$35.10
No. 1434	Motor driven unit consisting of: 1426 sander, 1432 stand, without motor or miter gauge.	\$27.35
	Shipping Weight 100 lbs. Code Word DISKY.....	

UNUSUAL VALUE Offered By This 6-Inch BELT SANDER

Here is a 6" belt-type sanding machine that is heavy and husky enough to do any of the dozens of sanding, polishing and finishing operations to be found around the average shop—amateur or industrial, and yet which is portable enough to be used just where it is wanted.

Every feature of its design has been studied to overcome the disadvantages usually found in machines of this type. The frame is heavy and substantial, the adjustments are convenient and positive in action, attachments are quickly installed or removed, it may be used either vertically or horizontally as required, it can be adapted for use on wood, metal, plastics and many other materials—it is the ideal type of small all-around finishing machine for the shop.

Used Vertically or Horizontally

This machine may be set horizontally, as shown in the photo at top of page, and equipped with a wood fence for edge or face sanding, if required. Or it may be used vertically, in connection with the 7½" x 14¾" tilting table as shown below, for a wide variety of operations in both wood and metal.

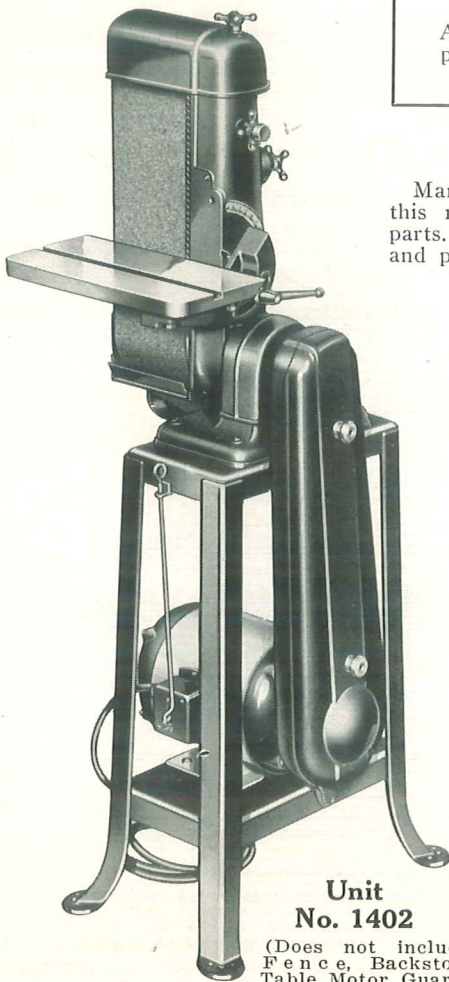

**Unit
No. 1402**

(Does not include Fence, Backstop, Table, Motor, Guard, Switch Rod.)

No. 1400

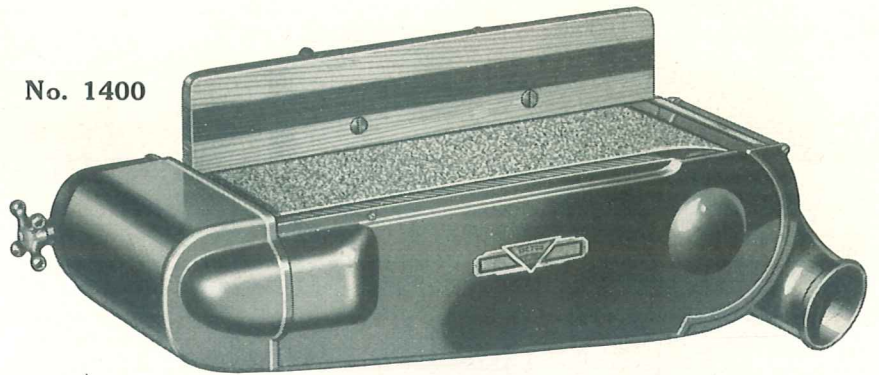

Specifications

Overall dimensions: 28" long; 13" wide; 8½" high horizontal; 26¼" high vertical.

Completely ball-bearing equipped. Double-seal bearings, lubricated at the factory for life.

Completely enclosed and guarded in accordance with all safety requirements.

Exceptionally heavy main drive shaft, carrying large diameter drum (5½"). Large driving pulley to transmit power.

No rubber covering required on drums, thus eliminating one source of replacement expense.

Adjustable deflector on drum hood catches practically all sawdust. Hood is provided with suction spout.

Machine operates vertically as well as horizontally.

Cloth-backed belts, 6" wide by 48½" long. Aluminum-oxide belts for metal finishing.

Tilting table, 7½" by 14¾", with ¾" by ¾" groove for miter gage is available for use in vertical position.

Adjustable fence for edge sanding and adjustable back stop for flat sanding are available for use in horizontal position.

Welded steel stand available to make machine completely portable.

Belt Guard available to complete guarding of machine.

Adapted for Many Industrial Finishing Operations

Many machine and manufacturing shops use this machine for polishing and sizing metal parts. Die-casters, also, use it as a finishing and polishing machine, with a great saving in

power cost over larger machines. For finishing, fining and surfacing plastic parts, also, it has found wide acceptance. Adaptable for practically any small industrial finishing operation.

Completely Enclosed and Thoroughly Guarded

No more completely enclosed or thoroughly guarded sander is available, regardless of size or price. Only the portion of the sanding belt that is being used is open, the ends and bottom of the belt, as well as the drums, being completely

covered. The guard covering the end drum may be removed in a moment, for use in finishing long materials, or for sanding curved work. This complete enclosure also increases the efficiency of the dust-removal system.

No. 1400	Belt Sander only, as shown above, but without fence, back stop or table. With one No. 80 grit garnet belt. Without belt or motor pulley	\$32.85
	Shipping Weight 110 lbs. Code Word SANDA.	
No. 560	V-belt (56" inside circumference)	1.00
	Shipping Weight 1 lb. Code Word EICVB.	
No. 5500	5" diameter motor pulley, ¾" bore75
	Shipping Weight 1½ lbs. Code Word PULOH.	
No. 1401	Tilting table for No. 1400 Sander	6.85
	Shipping Weight 20 lbs. Code Word SANDB.	
No. 1403	Back Stop, complete with bracket	1.85
	Shipping Weight 4 lbs. Code Word SANDD.	
No. 1410	Wood Fence (3¼" by 17½") with brackets	2.60
	Shipping Weight 5 lbs. Code Word SANDL.	
No. 1406	Steel Stand (Top, 7⅞" by 15⅞" by 24¼" High)	6.50
	Shipping Weight 30 lbs. Code Word SANST.	
No. 1402	Belt-Sander Unit, consisting of No. 1400 Sander, No. 560 V-belt, No. 5500 5" V-Pulley, ¾" bore, and No. 1406 Steel Stand. Without fence, backstop or table. Without motor, belt guard or switch rod	41.10
	Shipping Weight 144 lbs. Code Word SANDC.	
No. 1411	Belt guard for Sander, complete with screws	8.95
	Shipping Weight 35 lbs. Code Word SANDM.	

Note: No. 9100 (old No. 924) or No. 9400 (old No. 922) motors recommended for this machine. Use No. 1334 switch rod. See pages 28-30.

6-Inch Belt Sander Is Ball-Bearing Equipped

The No. 1400 6" Belt Sander is completely ball-bearing equipped. And the bearings used are the New Departure double-seal ball bearings that have proved themselves through years of service in our machines. They are lubricated at the factory for their entire life and require no further attention.

Left—View from rear, showing adjustable back stop and its bracket. This is available for use in sanding flat work, to prevent it from being carried along with the belt.

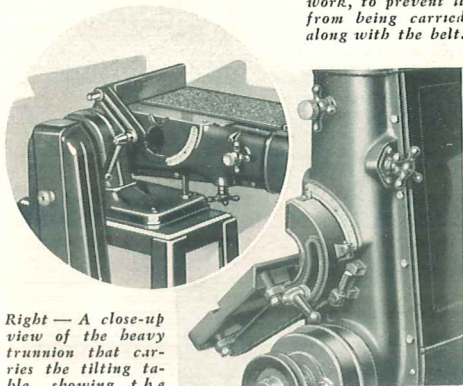

Right—A close-up view of the heavy trunnion that carries the tilting table, showing the swinging stop link and adjustable stop screws. A tilting scale and adjustable pointer are also provided.

Abrasive Belts for Sander

The garnet belts for wood finishing are far superior to ordinary sandpaper belts; they cut faster and last longer. The aluminum-oxide used on the belts supplied for metal finishing and polishing are also superior to emery belts. Aluminum-oxide is extremely hard and tough and does better and faster work than emery, besides having longer life.

Belts are 6" wide and 48 $\frac{5}{8}$ " long. Furnished in two garnet grits for wood finishing and two aluminum-oxide grits for metal.

- | | | |
|-----------------|--|---------------|
| No. 1412 | 6" Diagonal-lap garnet belt for wood. 80 grit (fine) cloth-backed. Fits No. 1400 sander. Ship. Weight 1 lb. Code Word SANDN... | \$1.10 |
| No. 1413 | 6" Diagonal-lap garnet belt. No. 40 grit (coarse) cloth-backed. Fits No. 1400 sander. Shipping Weight 1 lb. Code Word SANDO... | 1.25 |
| No. 1414 | 6" diagonal-lap al. oxide belt for metal. 100 grit (fine) cloth-backed. Fits No. 1400 sander. Ship. Weight 1 lb. Code Word SANDP | 1.10 |
| No. 1415 | 6" Diagonal-lap al. oxide belt for metal. 50 grit (coarse) cloth-backed. Fits No. 1400 sander. Ship. Weight 1 lb. Code SANDQ... | 1.10 |

Sawdust Blower a Convenience



Due to the complete enclosure of the No. 1400 belt sander, an exhaust blower for the sawdust is really practical. By actual test, 90% of the sawdust made by the sander is drawn into the cloth bag. The motor of the No. 1420 blower is of the universal type, and will operate on either

110 volts A. C. or D. C. Note that it can be supplied for 110-volt current only. Of special value for the production and school shop.

- | | | |
|-----------------|--|----------------|
| No. 1420 | Exhaust Blower for No. 1400 Belt Sander, complete with mounting adapter, cloth bag, built-in switch, cord and plug. For 110-v. A. C. or D. C. only | \$29.50 |
| | Shipping Weight 11 lbs. Code Word SANDV. | |

SANDING DRUMS a Convenience for Any Shop

Wide Drums for Drill Presses and Lathes



Our rubber-cushioned sanding drums (U. S. Pat. No. 1,906,190) employ a principle that insures every part of the drum being evenly expanded. Many sanding drums expand more at the center than at the ends, which means that perfectly flat work is difficult to produce with them. Others, having fasteners for the sandpaper on their surface, will "bump" every time the fastening passes over the work.

In our drum, each rubber section is separated from its neighbor by non-corrosive bakelite washers, with metal bushings next to the arbor. The disks are expanded perfectly uniformly, produce perfect work and run dead true. No. 840 drum has $\frac{1}{2}$ " diameter stem to fit $\frac{1}{2}$ " hollow spindle or chuck. Others have $\frac{1}{2}$ " bore. See page 37 for drums with No. 2 Morse taper shank to fit No. 930 lathe.

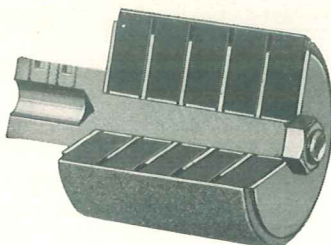

- | | | |
|----------------|--|---------------|
| No. 830 | 3" dia. x 3" Drum, with one sleeve. Fits $\frac{1}{2}$ " dia. shaft. Sh. Wt. 2 lbs. SADRA. | \$2.50 |
| No. 831 | 3" x 3" sleeves, coarse garnet. Code SASLA. Per 6... | .90 |
| No. 832 | 3" x 3" sleeves, medium garnet. Code SASLB. Per 6... | .90 |
| No. 833 | 3" x 3" sleeves, al. oxide (for metal) Code SASLC. Per 6 Sh. Wt. 3" sleeves, 8 oz. per 6 | 1.15 |

- | | | |
|----------------|--|---------------|
| No. 835 | 1 $\frac{3}{4}$ " dia. x 2" Drum, with 1 sleeve. Fits $\frac{1}{2}$ " dia. shaft. Sh. Wt. 1 $\frac{3}{4}$ lbs. SADRB. | \$1.60 |
| No. 836 | 1 $\frac{3}{4}$ " x 2" sleeves, med. garnet. Code SASLE. Per 6... | .75 |
| No. 837 | 1 $\frac{3}{4}$ " x 2" sleeves, fine garnet. Code SASLF. Per 6... | .75 |
| No. 838 | 1 $\frac{3}{4}$ " x 2" sleeves, al. oxide (for metal). SASLG. Per 6 Sh. Wt. 1 $\frac{3}{4}$ " sleeves, 4 oz. per 6. | .90 |
| No. 840 | 1 $\frac{1}{2}$ " dia. x 2 $\frac{1}{2}$ " drum, with one sleeve. With $\frac{1}{2}$ " shank to fit hollow spindle or chuck. Sh. Wt. 8 oz. Code SADRC. | \$1.25 |
| No. 841 | 1 $\frac{1}{2}$ " x 2 $\frac{1}{2}$ " sleeves, med. garnet. Code SASLK. Per 6... | .60 |
| No. 842 | 1 $\frac{1}{2}$ " x 2 $\frac{1}{2}$ " sleeves, fine garnet. Code SASLM. Per 6. | .60 |
| No. 847 | 1 $\frac{1}{2}$ " x 2 $\frac{1}{2}$ " sleeves, al. oxide (for metal). SASLO. Per 6 Shipping Weight 1 $\frac{1}{2}$ " sleeves, 4 oz. per 6. | .75 |

Note: Order sanding sleeves as "1 No. 831" where one package is wanted. Do NOT order "6 No. 831 sleeves," as this means 6 packages.

Narrow Drums for Hand Drills, Flexible Shafts, Etc.

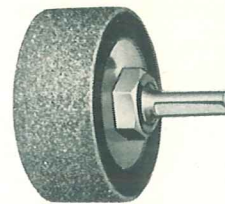

Designed for use where narrower-faced sanding drums than our Nos. 830, 835 or 840 are required, these new drums have several advantages over ordinary drums of the same type.

Painstaking attention to every point that might add to the usefulness of the tool and the convenience of the user is reflected in such details as the recessed mounting of the end washer, as shown in the cross section. This enables the drum to be used right up into the corners, which cannot be done if the outside washer is not recessed.

Another detail is the shape of the shank. This permits the sanding drum to be used in all $\frac{1}{8}$ " collets, in all $\frac{1}{2}$ " and $\frac{3}{8}$ " three-jaw chucks and in most $\frac{1}{4}$ " three-jaw chucks.

The drums themselves are of live flexible rubber, which is expanded to hold the abrasive sleeves by tightening the spindle nut. Sleeves are of aluminum oxide and cut accurately and fast.

Especially adapted for use in flexible shafts, portable electric hand drills, drill presses, lathe, polishing heads, etc.

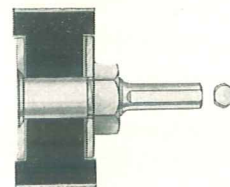

Cross-section shows how end washer is recessed to enable drum to be used into corners, also unique shaft section.

- | | | |
|----------------|---|---------------|
| No. 679 | 1 $\frac{1}{2}$ " dia. x 1" face Drum, $\frac{1}{8}$ " shank, with one sleeve | \$.75 |
| | Sh. Wt. 6 oz. Code SANAA. | |
| No. 682 | 1 $\frac{1}{2}$ " dia. x 1" sleeves, No. 40 grit. Per 6 | \$.55 |
| | Ship. Wt. 4 oz. Code SANAD. | |
| No. 683 | 1 $\frac{1}{2}$ " dia. x 1" sleeves, No. 80 grit. Per 6 | \$.55 |
| | Ship. Wt. 4 oz. Code SANAE. | |
| No. 680 | 2 $\frac{3}{8}$ " dia. x 1" face Drum, $\frac{1}{8}$ " shank, with one sleeve. Sh. Wt. 8 oz. SANAB. | \$.85 |
| No. 684 | 2 $\frac{3}{8}$ " dia. x 1" sleeves, No. 40 grit. Per 6. Sh. Wt. 5 oz. Code Word SANAF | \$.55 |
| No. 685 | 2 $\frac{3}{8}$ " dia. x 1" sleeve, No. 80 grit. Per 6. Sh. Wt. 5 oz. Code SANAG | \$.55 |
| No. 681 | 3" dia. x 1" face Drum, $\frac{1}{8}$ " shank, with 1 sleeve. Sh. Wt. 12 oz. Code SANAC. | \$1.10 |
| No. 686 | 3" dia. x 1" sleeves, No. 40 grit. Per six. Sh. Wt. 7 oz. Code Word SANAH | \$.70 |
| No. 687 | 3" dia. x 1" sleeves, No. 80 grit. Per six. Sh. Wt. 7 oz. Code Word SANAI | \$.70 |

RUGGED, DEPENDABLE: These Motors Give You More For Your Money Because They Are Built For Long, Trouble-free Service

Powerful, well-designed fan and scientific baffling keep motor cool under load.

Field windings of highest grade enameled wire, carefully wound, insulated and tested.

Heavy, unbreakable welded-steel casting, of original design for heavy-duty service.

Oversize air passages throughout motor insure proper cooling, and keep motor power at maximum.

Large opening over commutator to provide utmost convenience in making connections or renewing brushes.

Entirely new type of shaft protector covers extra shaft and affords maximum safety (Pat. pending.)

Finest of enameled, cotton-covered wire and highest grade insulation used for rotor windings.

Switch mounted on separate spider to permit removal of conduit-box cover without disturbing switch.

Heavy-duty 8-foot cord and soft-rubber plug. Cord anchored to conduit box with heavy clamp.

Heavy-duty Cutler-Hammer two-pole switch. Completely cuts off all current so that there are no "live" leads into motor when the switch is "off".

Oversize conduit box. Plenty of room to make connections. Separate spider for switch.

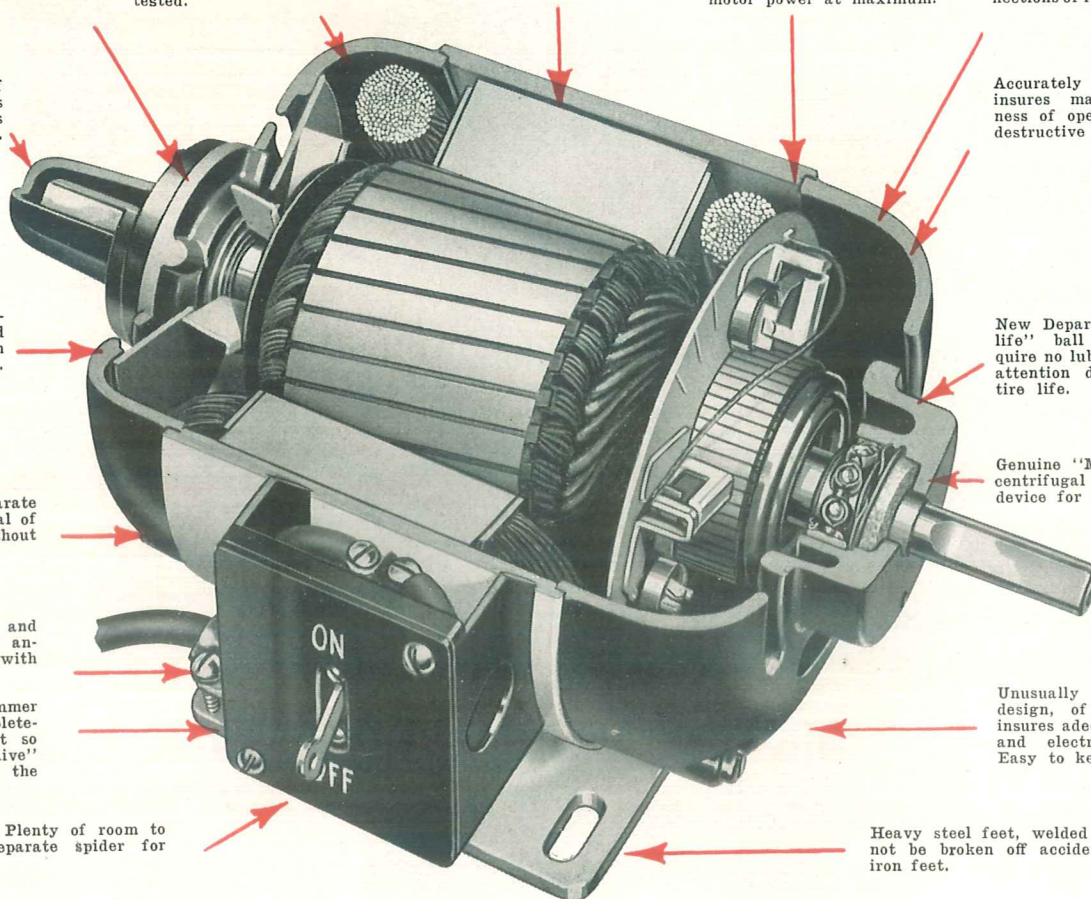

Accurately balanced rotor insures maximum smoothness of operation; prevents destructive vibration.

New Departure "sealed-for-life" ball bearings. Require no lubrication or other attention during their entire life.

Genuine "Master" patented centrifugal short-circuiting device for commutator.

Unusually generous frame design, of modern design, insures adequate mechanical and electrical clearances. Easy to keep clean.

Heavy steel feet, welded to frame. Cannot be broken off accidentally like cast-iron feet.

As the typical cross-section above shows, our motors are designed and built in accordance with the very best practice in motor design. They are comparatively low in cost—but they are NOT built down to a price; quality must be maintained in every particular, and we believe that they are the finest motors obtainable at anywhere near their price.

Casings are of heavy welded steel, with steel feet welded on. These cannot be broken off by accidental impact, as may happen with cast-iron feet on cast end brackets.

These motors will deliver more than their full rated horsepower on all machines for which they are specified. Their overload capacity, due to their generous design and fine construction, is far greater than many similar motors—the overload capacity in most types being 250% of rated horsepower or over.

Our motors in 8½" frame, rated at ½-H.P. and over, should not be confused with high-speed motors of the same rating built

into small frames. Our motors are all of standard speed (1725 r.p.m.) for regular installations. We do not consider that a small-frame, high speed motor is the equal of a standard speed motor built into a large frame, or that it offers any real saving to the customer even though the original price may be lower.

Note that our switches are of heavy-duty two-pole construction (Cutler-Hammer) and are mounted on a separate spider in the extra-large-size conduit box. This switch not only cuts the current completely from the motor when the switch is "off" (which a cheap single-pole switch will not do), but also permits the removal of the conduit box cover for wiring, inspection, etc., without disturbing the switch. This is required by many electrical codes.

Study the features illustrated above. Compare the design and construction of these motors with others and you will realize why they offer such extraordinary value for their comparatively low cost.

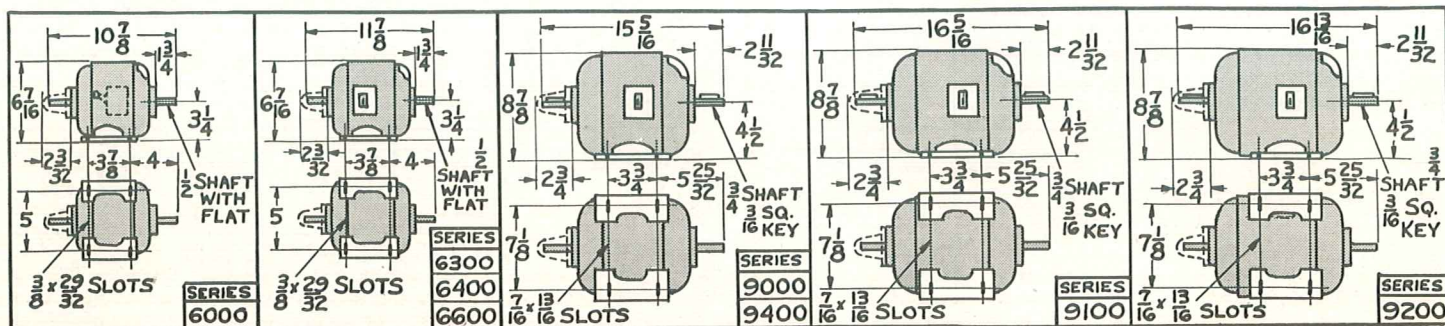

POWERFUL MOTORS: The Best In Modern Motor Design

Highest Value in These 1/3 to 1 H. P. Ball Bearing Repulsion-Induction Motors

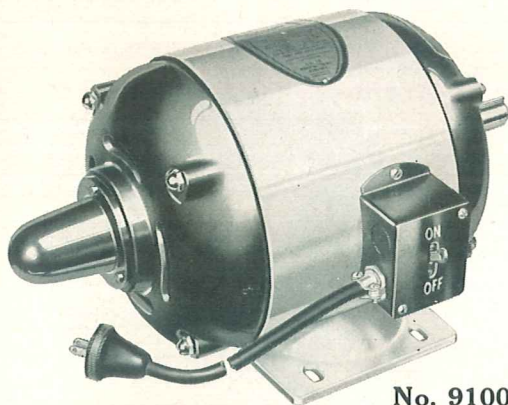

No. 9100

These motors are completely described on page 28, on which the sectional illustration shows the many features that make our repulsion-induction motors such outstanding value. Note that all of these motors are equipped with heavy-duty rubber-covered cord and soft-rubber plug, together with double-pole switch.

Our motors built into 8 1/2" diameter frame should not be compared with high-speed motors rated at the same power, but built into 6" frames for special service.

Made for use on either 110 or 220-volt lines, they are normally supplied connected for 110 volts.

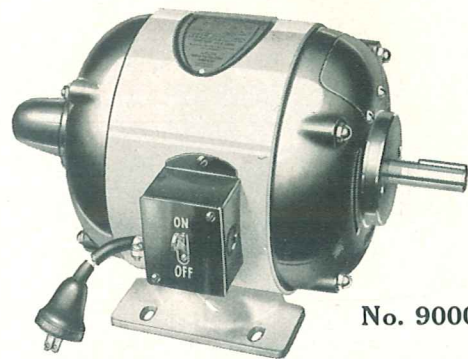

No. 9000

Design and Letters Patent Pending

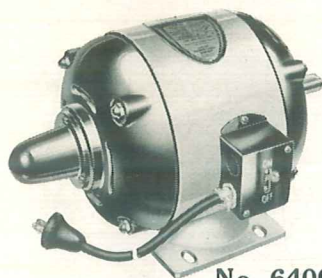

No. 6400

New No.	Old No.	H.P.	R.P.M.	Volts	Cycles	Frame	Shaft	Bearings	Price	Code	Ship. Wt.
6400	900	1/3	1725	110/220	60	6"	1/2"	Ball	\$19.95	SACCA	34 lbs.
6410	901	1/3	1425	110/220	50	6"	1/2"	Ball	19.95	SACCD	34 lbs.
6420	906	1/3	1425	110/220	25	6"	1/2"	Ball	29.85	SACCF	34 lbs.
9000	820	1/2	1725	110/220	60	8 1/2"	3/4"	Ball	31.85	NACAA	68 lbs.
9010	821	1/2	1425	110/220	50	8 1/2"	3/4"	Ball	31.85	NACAC	68 lbs.
9020	829	1/2	1425	110/220	25	8 1/2"	3/4"	Ball	33.85	NACAE	68 lbs.
9100	924	3/4	1725	110/220	60	8 1/2"	3/4"	Ball	37.85	NACBA	80 lbs.
9110	925	3/4	1425	110/220	50	8 1/2"	3/4"	Ball	37.85	NACBC	80 lbs.
9200	1094	1	1725	110/220	60	8 1/2"	3/4"	Ball	43.85	NACDA	85 lbs.
9210	1095	1	1425	110/220	50	8 1/2"	3/4"	Ball	43.85	NACDE	85 lbs.

1/2-H.P. Sleeve-Bearing Repulsion-Induction Motor

Built to the same high-grade material specifications as our regular ball-bearing repulsion-induction motors, this motor will give splendid service where a ball-bearing motor is not required. It is fitted with 8-ft. cord and soft-rubber plug, with double-pole switch, but switch is not mounted on separate spider in box. Equipped with plain bronze bearings with wick oiling system.

Furnished with plain wood shaft protector instead of non-rotating type.

Should not be used for vertical installation or with No. 1426 Disk Sander.

No. 8050 (Old No. 1120) Sleeve-bearing Repulsion - Induction Motor, for 110-220 volt, 60-cycle A. C. 1725 R.P.M. With switch, cord and plug **\$24.85**
Shipping Wt. 65 lbs. Code Word EACBA.

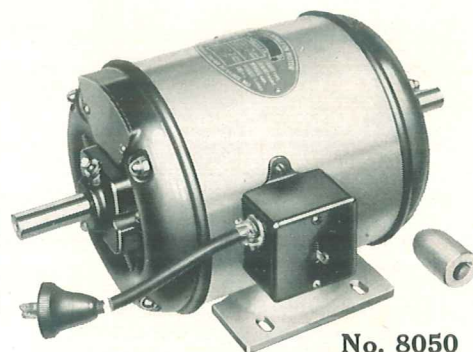

No. 8050

1/3 to 1 H.P. 3-Phase Heavy-Duty Motors

Three-phase motors are particularly adapted for industrial and school installations, and should be specified for all heavy-duty, continuous production applications, especially where large gangs of machines are installed (which should not be operated from lighting circuits).

When so used, three-phase motors will save from 30 to 40 per cent of the power consumed by split-phase and

similar motors, besides delivering greater power and lowering maintenance costs.

Identical in material specifications with our repulsion-induction motors, they are not supplied with switch, cord or plug, as they must be connected in conduit.

Note that 1/2-H. P. three-phase motor in 6" frame cannot be used on 17" drill press.

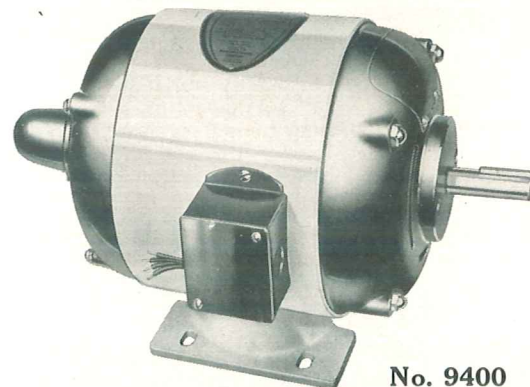

No. 9400

NOTE

We can supply direct-current and alternating-current motors in a wide variety of voltages and frequencies in addition to the standard motors listed on these pages. Write for quotations on motors not listed here. Three-phase motors cannot be furnished with switch, cord or plug, as they must be connected by an electrician.

New No.	Old No.	H.P.	R.P.M.	Volts	Cycles	Frame	Shaft	Bearings	Price	Code	Ship. Wt.
6500	802	1/3	1725	220	60	6"	1/2"	Ball	\$18.85	SACDA	31 lbs.
6600	920	1/2	1725	220	60	6"	1/2"	Ball	23.85	SACHA	33 lbs.
6610	921	1/2	1425	220	50	6"	1/2"	Ball	23.85	SACHF	33 lbs.
9400	922	3/4	1725	220	60	8 1/2"	3/4"	Ball	38.85	NACHA	80 lbs.
9502	1512	1	1725	220/440	60	8 1/2"	3/4"	Ball	44.85	NACKC	85 lbs.

DEPENDABLE SERVICE: Your Guarantee In These Powerful Motors

1/4 and 1/3-H.P. "Double-Duty" Split-Phase Motors

These 1/4 and 1/3-H.P. Split-Phase Motors are built to exactly the same material specifications and exacting standards of workmanship as the motors described on the previous pages.

All, with the exception of Nos. 6000, 6010 and 6020, (which have wick-lubricated bronze bearings) are equipped with New Departure "sealed-for-life" ball bearings. Fitted with double-pole on and off switch,

cord and soft-rubber attachment plug. Double shafts, 1/2" diam. x 1 1/2" long. Extra shaft covered by non-rotating protector (pat. pending).

New No.	Old No.	H.P.	R.P.M.	Volts	Cyc.	Bearings	Price	Code	Ship. Wt.
6000	1100	1/4	1725	110	60	Bronze	\$ 8.50	SACAA	27 lbs.
6010	1101	1/4	1425	110	50	Bronze	8.50	SACAD	27 lbs.
6020	1108	1/4	1425	110	25	Bronze	12.85	SACAG	27 lbs.
6300	800	1/3	1725	110	60	Ball	13.85	SACBA	31 lbs.
6310	798	1/3	1425	110	50	Ball	13.85	SACBD	31 lbs.
6320	795	1/3	1425	110	25	Ball	19.85	SACBG	31 lbs.

Only 1/3 or 1/2-H.P. motors in 6" frame should be specified for use on 14" drill presses. Do not order 1/4-H.P. motors

for this service. Do not specify bronze-bearing motors in vertical installations. Write for prices on other voltages, etc.

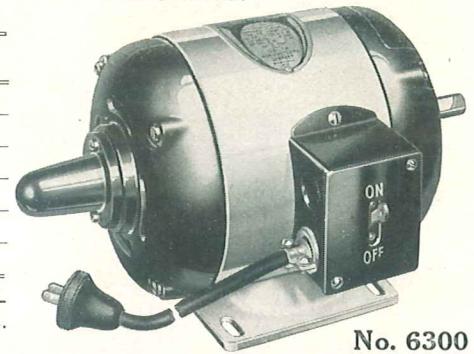

No. 6300

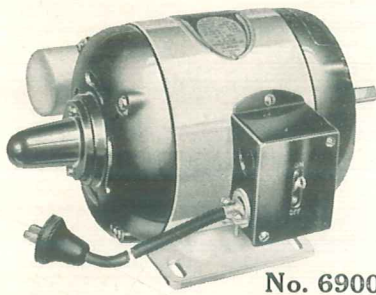

No. 6900



Reversing switch at left is standard on Nos. 6900 and 6910 motors. Can also be used on any standard split-phase motor having both ends of starting winding brought out. Cannot be used on our regular repulsion-induction motors.

High-Speed Reversible 1/2 and 1-H.P. Shaper Motors

Specially designed for use on No. 1180 shaper, these motors are intended for high-speed work. They are made in three types; a capacitor-type motor in 6" frame, intended for light shaper duty, a heavy powerful repulsion-induction motor, reversible at will and a 1-H.P. heavy-duty three-phase motor. Speeds of all motors are 3450 r.p.m. Shaft size, 1/2-H.P. motor is 5/8"; 1-H.P. motors have 3/4" shafts. 1/2-H.P. motor fitted with reversing switch shown at left. 1-H.P. repulsion-induction motor fitted with reversing mechanism on brush ring.

1-H.P. motors should always be specified for production work on the shaper. They should be connected to 220-volt power line wherever possible.

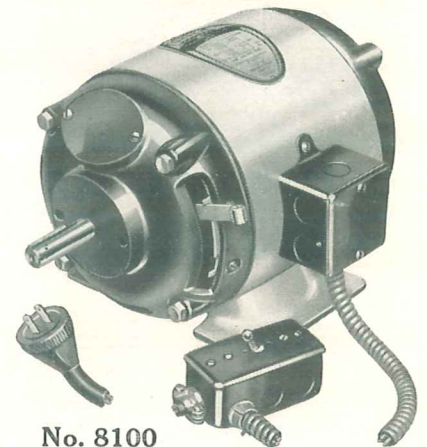

No. 8100

- No. 6900** (Old No. 915) 1/2-H.P. 3450 R.P.M. Ball-Bearing Capacitor Motor, for 110v, 60-cycle, A. C. only. With special 4-wire cord, reversing switch, 8-ft. 2-wire cord and plug, connected ready for use. Complete **\$24.85**
Shipping Weight 42 lbs. Code Word SACLA.
- No. 6910** (Old No. 916) 1/2-H.P. 2850 R.P.M. Ball-Bearing Capacitor Motor, with reversing switch, 4-wire cord, 2-wire cord and plug. Same as No. 915 but for 110v, 50-cycle A. C. **\$24.85**
Shipping Weight 42 lbs. Code Word SACL1.
- No. 6920** (Old No. 917) 1/2-H.P. 3450 R.P.M. Ball-Bearing Capacitor Motor, same as No. 915, but without reversing switch or 4-wire cord. With plain 2-pole toggle switch and 8-ft. cord and plug. **\$22.75**
Shipping Weight 41 lbs. Code Word SACMA.

- No. 1116** Reversing switch only, for use on No. 917 motor, or with any standard split-phase motor. With four wire cord, connected..... **\$ 3.95**
Shipping Weight 2 lbs. Code Word SWREV.
- No. 8100** (Old No. 1075) 1-H.P. Ball-Bearing, 3450 R.P.M. Shaper Motor. With built-in reversing mechanism, on-and-off switch connected to motor with BX cable, 9-ft. cord and rubber plug. Single shaft, 3/4" diameter. For 110-220v, 60-cyc. A. C. **\$48.85**
Shipping Weight 85 lbs. Code Word EACCA.
- No. 9532** 1-H.P. Three-phase Ball-Bearing, 3450 R.P.M. Shaper Motor. Not furnished with reversing switch, on-and-off switch or cord and plug, as it should be connected to 220 or 440v, 60-cycle line by licensed electrician **\$42.85**
Shipping Weight 85 lbs. Code Word NACKS.

Switch Rods for Finger-Tip Control

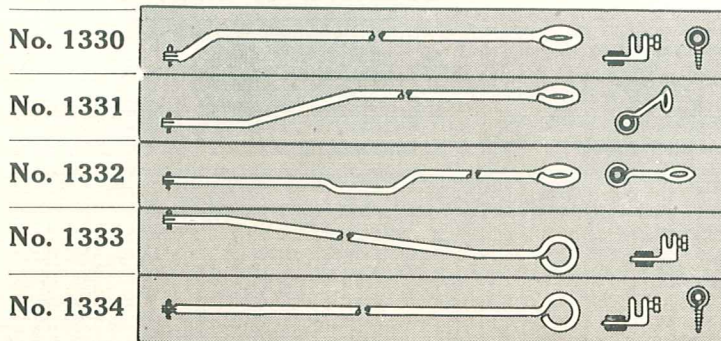

FOR UNITS NUMBER	Code Word	Price	Ship. Wt.
No. 878: No. 950 No. 1175	RODNA	\$.45	1 1/2 lbs.
All 11" and 14" Drill Presses	RODNB	.45	1 1/2 lbs.
All 17" Drill Presses	RODNC	.45	1 1/2 lbs.
No. 292: No. 660	RODND	.45	1 1/2 lbs.
No. 368: No. 714: No. 777 No. 881: No. 892: No. 1164 No. 1350: No. 1402: No. 1432 No. 1465 and all our benches with wood tops	RODNE	.45	1 1/2 lbs.

BETTER VALUE: Here Are Some Of The Practical Reasons Why Our BAND SAWS Offer More Convenience; Greater Safety And Higher Efficiency

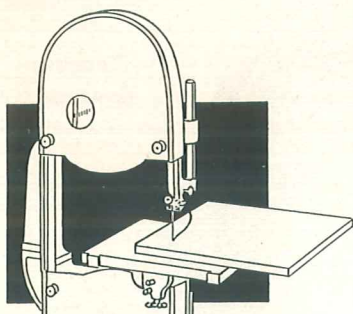

Over 90% of all band-saw work is done on the outside of the table as shown above. A 14" machine will handle this work just as effectively as a machine four times its size. If greater throat capacity is required for work of unusual swing, then an additional capacity of one or two inches is seldom of practical value.

Why a 14" Band Saw Is the Most Practical Medium-Size Machine

The capacity of the No. 890 band saw—14"x6"—was selected after the whole field of band-saw work had been thoroughly studied and after hundreds of band-saw users had been consulted to determine the most useful capacity for a medium-sized machine.

Since over 90% of all band-saw work is done on the outside of the table, on the side away from the frame, the 14" capacity is fully as effective as that of any other band saw, no matter how large. In the comparatively few cases where the "swing" of the work required a larger throat capacity, it was found that a band saw of from 20" to 24" swing was required, and that the addition of one or two inches to the throat was of no practical value.

Similarly, since over 90% of all band-saw work is done on stock less than 6" thick, to provide greater capacity than this is merely to penalize the user who does not require it. So our standard machine is provided with a raising attachment which permits the user who requires 12" capacity to obtain it economically, while the user who never requires this capacity is not penalized by higher cost.

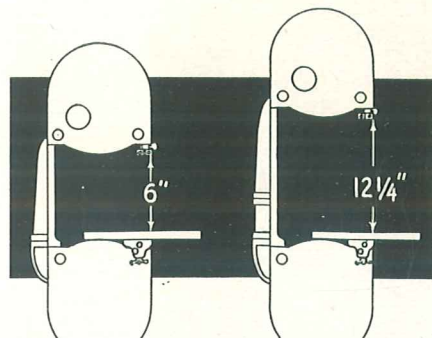

Our standard band saw has a 6" capacity under the guide. If capacity up to 12 1/4" is ever required for special work, it is economically obtained with our height attachment.

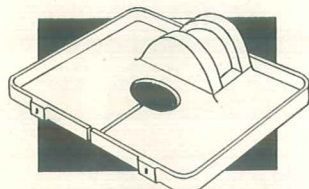

On all other band saws the saw entering slot runs to the front of the table. This forces the use of a single trunnion as above, or a slotted trunnion which makes a less rigid construction.

How Double Table Trunnions Provide Greater Rigidity—More Convenience

In our tables, the slot for entering the blade runs to the side of the table (patented). In all other machines the slot runs to the front. This older type has several disadvantages: The use of the front slot practically forces the use of a single trunnion, mounted at one edge of the table. This means loss of support to the front of the table—less rigidity. Even if double bearing surfaces are used on the trunnion, there is still only one trunnion. If two trunnions are used, the front one must be slotted to permit the passage of the blade, which weakens the trunnion.

The second disadvantage is that if a front guide bar is fitted to carry a rip gage, the bar must be unscrewed and removed every time a blade is changed.

With our patented construction, on the contrary, the table is solidly supported on two widely spaced trunnions. Since the entering slot is at the side of the table, the rip-gage bar need never be removed to change blades. It is obvious that this saves time and means much greater convenience in use.

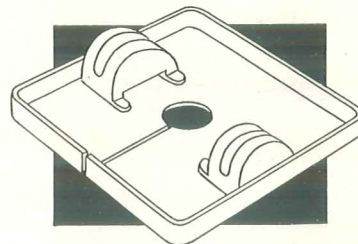

Our patented system of construction permits the use of two solid, widely spaced trunnions, which gives the table maximum rigidity at any angle, better clamping and increased accuracy.

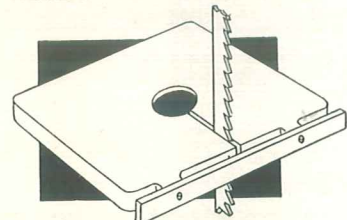

With the front table slot, rip-gage guide bar must be removed every time the blade is changed.

Fully Adjustable, Micrometer Guides Make Adjustments Fast and Accurate

On most medium-sized band saws and on many larger ones, the guides are not what we consider fully adjustable. That is, the blade support moves with the bracket carrying the blade guides, so that the adjustment of the blade support automatically means that the guides must be re-adjusted and vice versa. This means that the two adjustments must be "juggled" in order to obtain an exact setting. And, since the exact setting of the guides is a large factor in good work and long blade life, we regard such mountings as highly unsatisfactory.

In our guides—completely described and illustrated on the following pages—the guides are adjusted to the thickness of the blades and set to the tooth depth without affecting the adjustment of the blade support. Similarly, the blade support can be set precisely without disturbing the guide adjustment. And both adjustments are "set to a hair" with micrometer adjustment screws.

Some band saws have guides above the table only. Some have guides above the table and blocks for cleaning the blade (not guides) below. In our machines, exactly the same high-grade guide design is used above and below the table—and the lower guide comes within 3/4" of the bottom of the work, to give maximum support to the blade. In addition the adjustments are brought out to the front of the table, so that the operator's hands need never be near the saw blades while the machine is in motion.

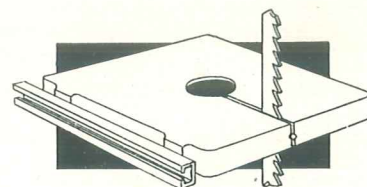

With our patented side slot, there is no necessity ever to remove the rip-gage guide bar.

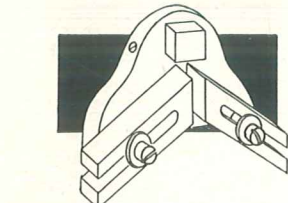

Many band saws have no guides under the table to support the blade after it goes through the work. This means less accuracy, as the blade is easily twisted or moved sidewise. Other saws have only wood blocks with steel blade support pin to serve as "guides" under the table.

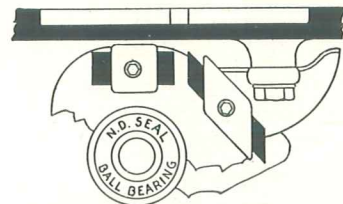

Not only have our saws the same high-grade guides under the table as above, but the lower guides come within 3/4" of the bottom of the work.

These Are Only a Few of the Less Obvious Reasons Why

It is naturally impossible in limited space, to show you all the reasons why these band saws have become so popular in hundreds of shops. We have shown only a few reasons, and others are illustrated on the following pages. We could point out the additional safety of our solid-surface guards, mounted rigidly on the frame of the machine (not on the tilting bracket or other moving part.) These guards completely cover the wheels front and rear. In many band saws the guards are of an open pattern which are not regarded as adequate by many safety authorities, and in others the rear of the wheel is not enclosed.

We could tell you about the sturdy tilting mechanism, which slides in a bracket cast as a part of the overarm

itself so that it cannot get out of line. We could tell you about the use of "sealed-for-life" New Departure ball bearings throughout the machine, so that lubrication or other bearing attention is never required. We could point out the care and accuracy used in machining and assembling the parts—the design of the wheel rims, which require no cementing on of the rubber tires, and many other things.

We honestly have tried to make our band saws the finest machines of their type on the market today, and if you will study the features of their design point by point, we are confident you will agree that these band saws represent more value for the money than you can find anywhere else.



New Departure "sealed-for-life" ball bearings are used throughout.

10-INCH BAND SAW: Built For The Craftsman Who Demands The FINEST For His Workshop

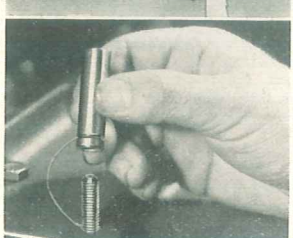
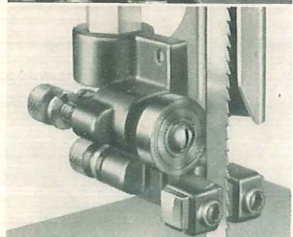
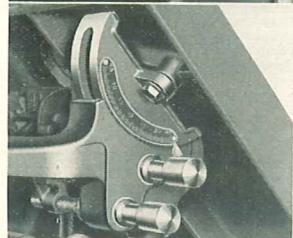
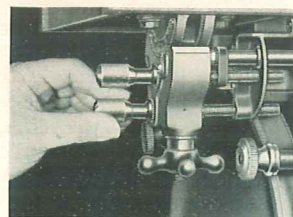

Adjustable Table Stop



No. 777

Specifications

Overall Dimensions: 33½" high; 11¾" wide; 23" front to back.

Capacity: 10" blade to upper arm; 6" under guide.

Table: Heavy cast iron, swinging on double trunnions. 11" by 11¾" surface.

Accurate, true-running balanced disk wheels, carried on self-sealed New-Departure ball bearings. Lubricated at factory for their entire life. Heavy, accurately ground main shaft.

Micrometer-adjustment upper guide. Each adjustment independent of others, and each made with precision.

Micrometer lower guide, with adjustments brought out to front of table. Operator's hands never come near blade. An exclusive feature.

Upper wheel tilting device and tension scale similar to that used on 14" band saw.

Both wheels and blade thoroughly guarded; only portion of blade actually used for cutting is ever exposed.

Welded stand available to make machine a self-contained unit.

⅓-H.P. motor sufficient for all average work.

Massive Frame

The frame of this machine is of exceptionally heavy and rugged design. It follows closely the construction of our 14" band saw which has been so extremely popular.

Double-Seal Ball Bearings

Machine is completely equipped with double-seal ball bearings—the finest type made—which insure complete absence of bearing trouble, and require no attention during their entire life. They are lubricated at the factory, and need never be re-lubricated. Blade supports are of the same type.

Patented Table Design

The table, which is of cast iron 11" by 11¾" in size, and is heavily ribbed and smoothly ground, swings on two widely spaced trunnions, one in front and one in back. This is made possible by our patented construction, and makes a table that is very much superior to the usual design. Adjustable table stop can be removed for a 10° left table tilt.

Micrometer Adjustments

Adjustments of the upper and lower guide are of the same micrometer type that have been so popular on the No. 890 14" band saw. Guide and blade-support adjustments are independent of each other, and all adjustments are made with the utmost precision. Lower-guide adjustments are brought out to the front of the table, so that the operator's hands need never come near the blade for any reason whatever—an important safety feature.

Complete Guarding

Upper and lower wheel guards on this saw are of the same design as on the 14" saw.

Many Other Features

The massive design, advanced engineering, thoroughly studied design and accurate construction of this machine make it the finest 10" band saw ever offered to the craftsman. Its capacity under the guide make it the equal of many machines of larger throat capacity. Examine it; compare it with others, and its superiority will be apparent at once.

Completely
Ball-
Bearing
Equipped

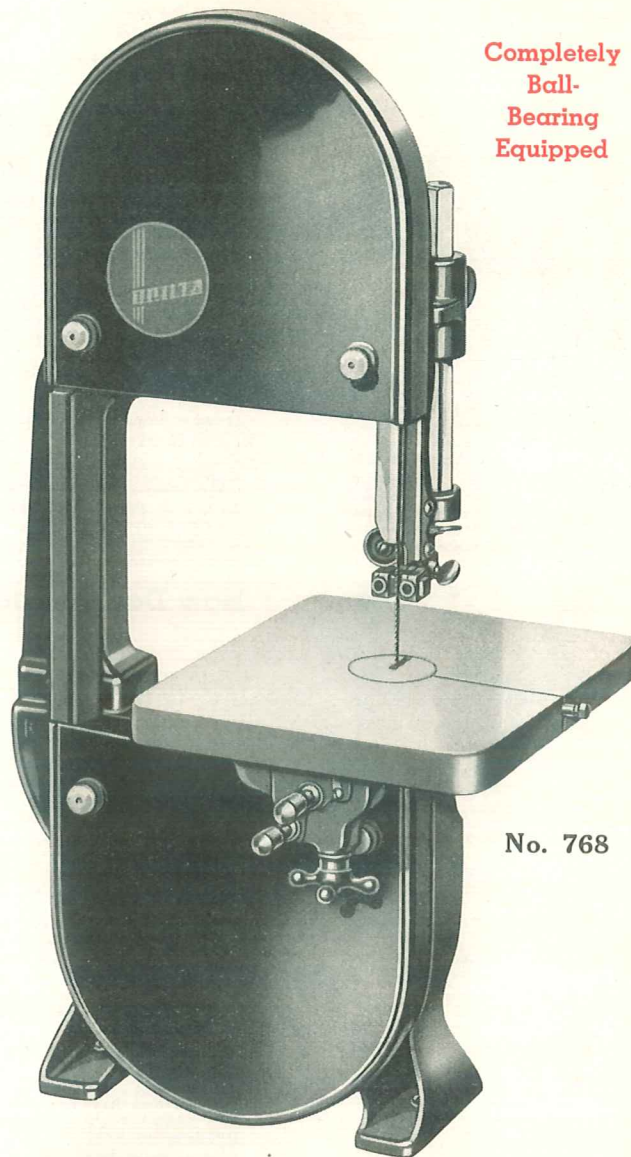

No. 768

No. 768 10" Ball-Bearing Safety Band Saw, with guard, ¼" blade and 5" arbor **\$29.90**
Shipping Weight 100 lbs. Code Word BANDA.

No. 5275 V-pulley, 2¾" dia. by ½" bore... **.45**
Ship. Wt. 11 oz. Code Word PULOD.

No. 560 V-belt, 22¾" center to center... **1.00**
Ship. Wt. 1 lb. Code Word EICVB.

No. 329 Steel stand (Top 7" by 12½"; 29¼" high) **5.75**

Shipping Weight 31 lbs. Code Word EICST.

No. 777 10" Ball-bearing Safety Band-Saw Unit, consisting of No. 768 Band Saw, No. 5275 2¾" pulley, ½" bore, No. 560 V-belt and No. 329 Steel stand **\$37.10**

Shipping Weight 140 lbs. Code Word BANDL.

No. 6300 or 6400 motor recommended for this unit and No. 1334 switch rod. See pages 28-30. No belt guard available for this unit.

Blades for No. 768 Band Saw, 74" Long (Cannot be used on No. 785 Saw)

Cat. No.	Width	Cut Radius	Code	Price Each
770	⅛"	¼"	BANDC	\$1.10
771	⅜"	½"	BANDE	1.10
772	¼"	¾"	BANDG	1.10
773	⅜"	1"	BANDH	1.10
774	¼"	¾"	BANDI	1.60

Shipping Weight 9 oz. each.
(No. 774 blade is for soft metals)

FOR A PRODUCTION TYPE METAL CUTTING BAND SAW SEE BACK COVER

14-INCH BAND SAW: First Choice For The Man Who Knows And Wants **GOOD TOOLS**

Upper wheel completely enclosed, having rear guard as well as removable front guard, complying with school and industrial requirements.

Upper-wheel adjustment has quick index to show blade tension. See photo below.

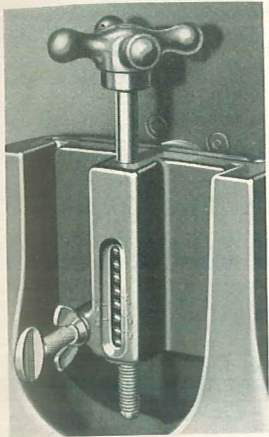

Hollow-cast upper arm of great stiffness and strength. Removeable to permit use of height attachment which increases capacity of machine to 12 1/4" thick.

Massive table, 14" x 14", swinging smoothly on double trunnions (patented). Very rigid table mounting, permitting removal of blade without disturbing rip-gage bars. Table tilts 45 deg. to right and 10 deg. to left. Positive stops. 3/8"x3/4" groove for miter gage.

Lower wheel completely guarded front and rear; mounted on ball bearings sealed on both sides and lubricated for the entire life of the bearing. Neither grit nor improper lubricant can enter these bearings, which increases their life three or four times over old-style bearings.

Unit No. 892

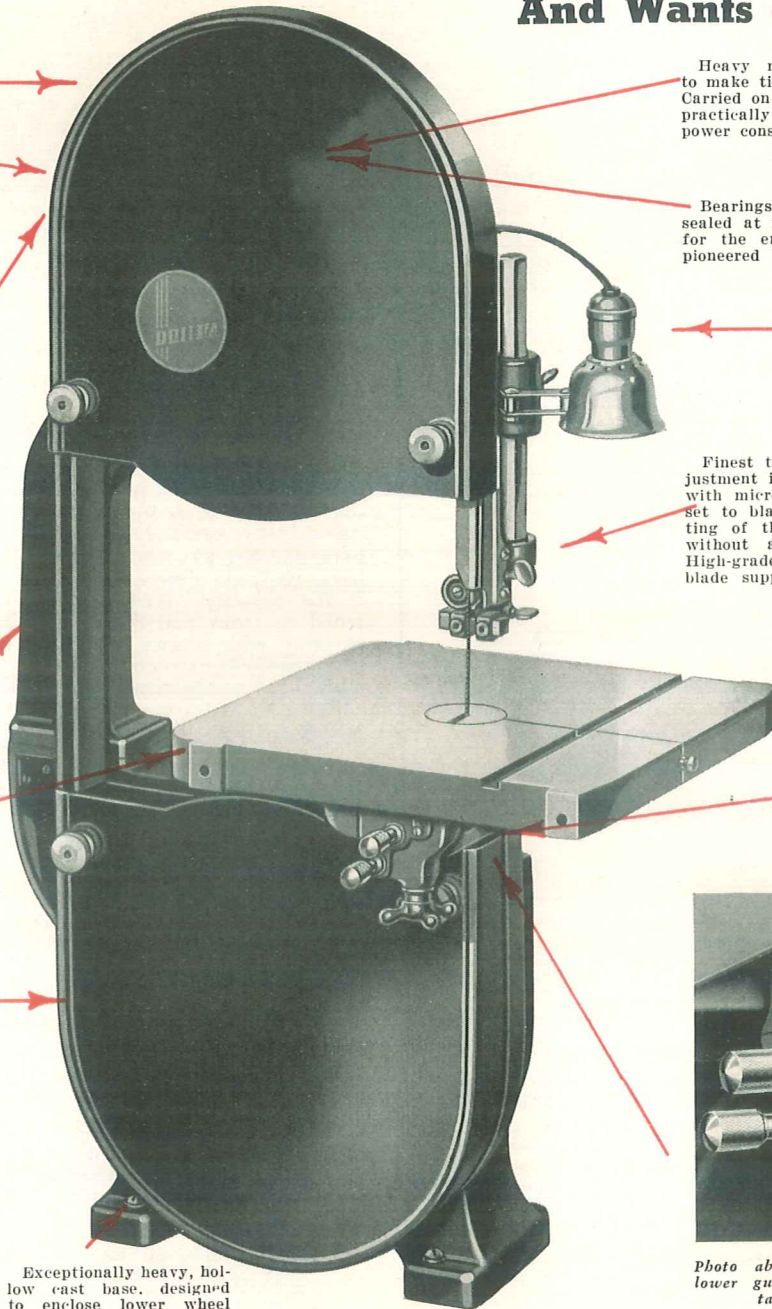
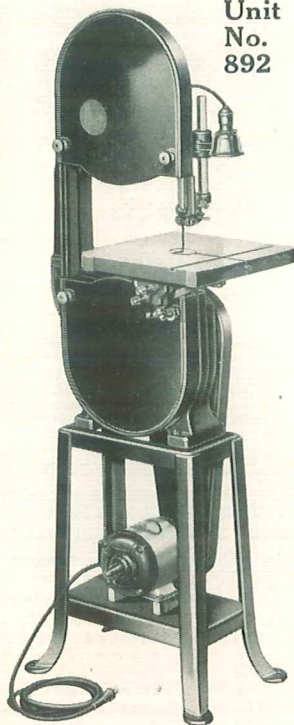

Heavy machined, cast iron wheels rimmed to make tire renewal easy; no cement required. Carried on double-seal ball bearings, wheels are practically frictionless, which means minimum power consumption and permanent alignment.

Bearings in upper wheel also lubricated and sealed at factory to insure trouble-free service for the entire life of the bearing—a feature pioneered by us.

Light attachment No. 882 available (extra) which permits machine to be used wherever most convenient for the job in hand and assures plenty of light on the work.

Finest type of guide ever offered. Each adjustment independent of others, and each made with micrometer accuracy. Guide pins can be set to blade teeth without disturbing the setting of the blade support, and blade support without altering adjustment of guide pins. High-grade reversible double-seal ball-bearing blade supports. (Patented.)

Lower guide of same construction as upper one, with added safety feature that all controls are brought out to front of table as shown in the photo below, so that operator's hands never come near blade—an important safety feature (pat. app. for). Guide comes within 3/4" of table top.

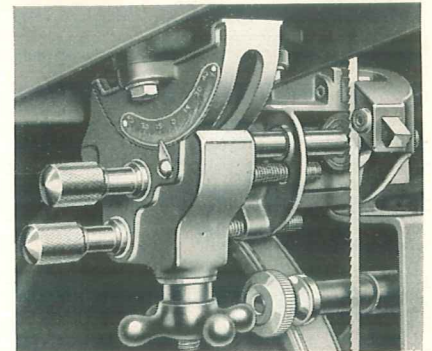

Photo above shows how the controls of the lower guide are brought to the front of the table—at the operator's finger tips.

Exceptionally heavy, hollow cast base, designed to enclose lower wheel completely. Rear face of pleasing design, easily cleaned.

No. 890

Height 41 1/4"; Width 16 1/4"; Front to Back 24 3/4"; Weight 152 Lbs.

This band saw has become the standard 14" saw used in industrial and school shops everywhere. It offers every advantage found in larger machines, plus a decided saving in first cost, in maintenance cost, and in power cost. Hundreds of shops have installed them as auxiliaries and as regular production units.

Both wheels are completely enclosed. Controls for the lower guide adjustments are brought out to the front of the table, so that the operator can make final adjustments while the machine is running without having his hands anywhere near the blade—an important safety feature. There are new heavy-duty

trunnions, spaced far apart to give the utmost rigidity to the table (a patented feature). There are many other refinements.

See this saw yourself, and you will know why it is the choice of all good professional craftsmen...who know good tools.

No. 890	14" Band Saw, with wheel guards, 1/4" blade and 8" arbor pulley, but without Light Attachment	\$48.85
	Shipping Weight 152 lbs. Code Word LABAN.	
No. 5275	2 3/4" V-pulley, 1/2" bore	.45
	Shipping Weight 11 oz. Code Word PULOD.	
No. 568	V-belt, 24 1/8" center to center	1.00
	Shipping Weight 1 lb. Code Word FORVD.	
No. 891	Steel stand, Top 7 7/8"x15 7/8"; 24" high	6.85
	Shipping Weight 30 lbs. Code Word LABST.	
No. 892	14" Band-Saw Unit for woodworking, consisting of No. 890 band saw, No. 5275 V-pulley (2 3/4" dia., 1/2" bore), No. 568 V-belt, and No. 891 steel stand. Without motor, belt guard, switch rod or light attachment	\$57.15
	Shipping Weight 183 lbs. Code Word LABUN.	
	No. 6400 motor and 1334 switch rod recommended. See pages 28 to 30.	

FOR A PRODUCTION TYPE METAL CUTTING BAND SAW SEE BACK COVER

BLADES For 10 and 14-Inch Saws—14-Inch Saw ACCESSORIES

Band-Saw Blades

Made of high-grade Swedish steel, accurately set, spaced and jointed, these blades will stand up under hard work. Standard blades for 14" band saws are 93" long; special blades for use with height attachment are 105" long.

14-inch Band-Saw Blades; 93-inch

Cat. No.	Width	Cut Radius	Code	Price Each
1032	1/8"	1/4"	BLABA	\$1.25
1033	3/8"	1/2"	BLABB	1.25
1034	1/4"	3/4"	BLABC	1.25
1036	3/8"	1"	BLABD	1.25
1038	1/2"	1 1/4"	BLABE	1.50
1040	3/4"	1 3/4"	BLABF	1.50

Shipping Weight 15 oz. each.

14-inch Band-Saw Blades; 105-inch

Cat. No.	Width	Cut Radius	Code	Price Each
1045	1/8"	1/4"	BLABJ	\$1.50
1046	3/8"	1/2"	BLABK	1.50
1047	1/4"	3/4"	BLABL	1.50
1048	3/8"	1"	BLABM	1.50
1050	1/2"	1 1/4"	BLABO	1.75
1052	3/4"	1 3/4"	BLABP	1.75

Shipping Weight 18 oz. each.

Metal-Cutting Blades; 93-inch

Cat. No.	Width	Teeth per in.	Code	Price Each
1060	1/2"	14	BLMET	\$1.85
1062	1/2"	18	BLMEU	1.85
1064	1/2"	24	BLMEX	1.85

Shipping Weight 1 1/2 lbs. each.

NOTE: These are hard-edge blades for cutting all metals.

Blades for No. 785 Saw 66" Long

(Will not fit No. 768 10" band saw)

Cat. No.	Width	Cut Radius	Code	Price Each
732	1/8"	1/4"	BABLK	\$1.00
733	3/8"	1/2"	BABLL	1.00
734	1/4"	3/4"	BABLM	1.00
736	3/8"	1"	BABLP	1.00
781	1/4"	3/4"	BAMEU	1.50

Shipping Weight 8 oz. each.
(No. 781 Blade is for soft metals.)

Blades for 12" Saw 78" Long

Cat. No.	Width	Cut Radius	Code	Price Each
532	1/8"	1/4"	BABLA	\$1.10
533	3/8"	1/2"	BABLE	1.10
534	1/4"	3/4"	BABLC	1.10
536	3/8"	1"	BABLE	1.10
381	1/4"	3/4"	BAMET	1.50

Shipping Weight 9 oz. each.
No. 381 Blade is for cutting soft metals.

INCREASE CAPACITY with this Attachment

This inexpensive attachment increases the capacity of the 14" band saw from 6" to 12 1/4". Although 99% of the average shop work can be done on a 6" capacity you have here a simple means whereby the capacity of the saw can be increased without the necessity of buying a larger unit. It consists of a 6" extension block which fits under upper arm, extension wood guard, extension telescoping blade guard, necessary bolts, etc., can be added any time—105" blades are used.

No. 894 Height attachment for 14" band saws, with cast block, dowels, bolt, extension front blade guard and wood back blade guard. Ship. Wt. 14 lbs. LABHA. **\$6.00**

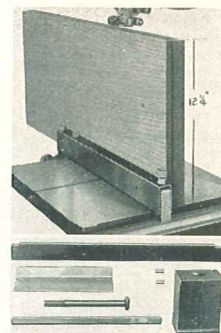

Rip Gages for the 14-inch Band Saw

Two rip-gage attachments are available for use with any of our 14" band saws for wood or metal. No. 893 has 18" guide bars, and No. 895 has 32" guide bars, the only difference being in the capacity. Bars are fastened to front and rear edges of table with screws, and, due to patented construction of the table, need not be removed to change blades. Fence has the same "Micro-Set" adjustment as the No. 860 circular-saw fence.

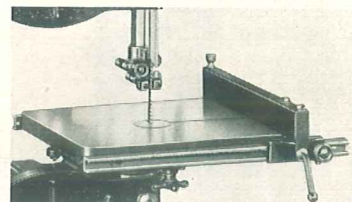

No. 893 Rip-Gage Attachment for No. 890 14" Band Saw, with 18" front and rear guide bars, "Micro-Set" fence and screws for attaching guide bars. Shipping Weight 10 lbs. Code Word LABGA. **\$4.25**

No. 895 Rip-Gage Attachment for No. 890 14" Band Saw, same as above but with 32" guide bars instead of 18". Shipping Weight 12 lbs. Code Word LABGB... **4.95**

Belt Guard for the 14" Band Saw

This belt guard, which completely encloses the belt on the 14-inch band saw front and rear, is designed to conform to all safety-code and industrial-commission requirements. When applied to the No. 892 band saw unit, with front and rear wheel and blade guards, the unit is made thoroughly safe, even for inexperienced help in the industrial shop or for students in the school shop.

The guard is made of cast iron, and is fastened to the steel stand with screws. The front of the guard is hinged to provide ready access to the belts and pulleys. Fastened by tightening one conveniently operated clamp knob.

No. 883 Belt guard for 892 band-saw, with screws to fasten to stand **\$9.60**
Shipping Weight 30 lbs. Code Word LABAB.



A SPIC AND SPAN SHOP Is Easy to Have with These Two Products

Gray Machine Enamel

Hundreds of users have purchased the attractive gray enamel with which we paint our machines, in order to paint benches, other tools and accessories in their shops to match. A number of industrial users have also standardized on our gray enamel for the machines in their shop. For the convenience of our customers we are now cataloging our standard enamel in three shades of gray. Light gray, which is the standard gray familiar to all wood-working machine customers; medium gray, which is the color of the latest Delta machines and standard dark machine-tool gray.



No. 101—Light Gray Machine Enamel
1 quart \$1.15
1/2 gallon 2.10
1 gallon 4.10
Code Word PAINA.

No. 102—Medium Gray Machine Enamel
1 quart \$1.15
1/2 gallon 2.10
1 gallon 4.10
Code Word PAINB.

No. 103—Dark (Machine-Tool Gray) Enamel
1 quart \$1.45
1/2 gallon 2.75
1 gallon 5.40
Code Word PAINC.

Shipping weights: 1 qt., 5 lbs.; 1/2 gal., 8 lbs.; 1 gal., 14 lbs.
Note: Paint is not mailable. Shipment must be made by express or freight.

Keep Your Tools Bright with "Rust-Go"

"Rust-Go" is a rust and grease-remover designed to remove instantly all traces of oxidation from the surface of polished iron and steel. It not only leaves a chemically clean surface, but destroys the chlorides which are primarily the cause of rust on tools and machines.

It will make your treasured tools, machine tables and other polished surfaces and parts clean and bright. It will clean your golf clubs, guns, skates, instruments, etc., from the rust spots and oxidized finger marks that mar their appearance and efficiency. It eliminates the tedious job of polishing with abrasive, reducing it to a simple rubbing with a cloth. Get a bottle at your dealer's today. Sold only through your dealer.



"Rust-Go" is not mailable and is not shipped direct. Your local dealer has it in stock and can supply you with the 1/2-pint size.

No. 100 "Rust-Go"

1/2 pint bottle \$.50
1/2 gallon bottle 2.40
1 gallon bottle 4.50

New A LOW COST GRINDER AND BUFFING HEAD

A Sturdy, Accurate Unit Which Meets All Requirements in the Home Workshop

HERE, in this new tool, you have for the first time a grinder that embodies all the precision design and construction found in our other tools at a price which is extremely attractive. From its heavy close grained cast iron housing—stand to its adjustable tool rests, it offers quality not found in similar units.

Its bronze bushings need only a minimum of lubrication. The wheels are 1/2" x 6", one of 50 grit (coarse) the other 60 grit (fine). Spindle diameter is 5/8" with 1/2" ends. Cast iron guards provide ample safety yet are readily removable should a buffing wheel be used. Adjustable rests are surface ground. Can be driven from bottom or back as desired—belt not furnished. Maximum safe speed is 3500 R.P.M. which gives a surface speed of 5500 ft. per minute.

The 3110 Buffing Head is similar to the grinder except that guards and rests are eliminated. Has right hand thread on right side for wheel 2 1/4" wide—left hand thread on left side for wheel 1" wide. Threads are 1/2"—24 so that many standard attachments such as scratch wheels, wire brushes and other wheels with 1/2" hole can be used.

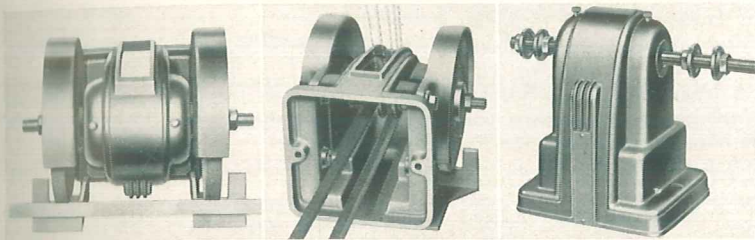
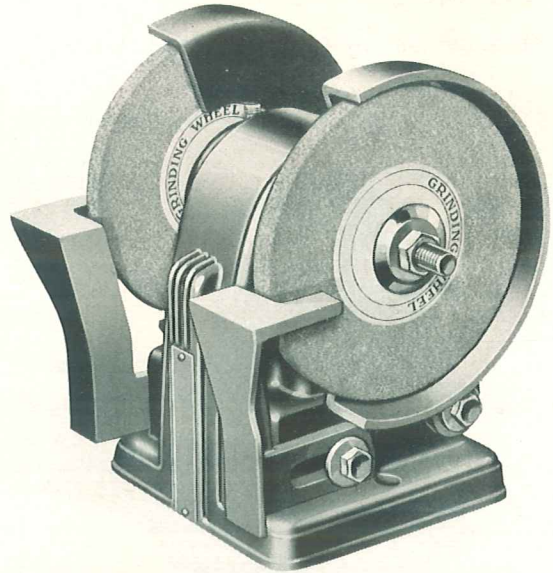

Wheels are so set that long work can be passed over wheels without interference.

Housing is designed so that unit may be driven from either back or bottom.

No. 3110 Buffing Head is a sturdy well constructed unit which has many uses.

- | | | |
|-----------------|---|---------------|
| No. 3100 | Bench Grinder with one 50 grit and one 60 grit wheel, tool rests, guards, but without belt. Ship. Wt. 17 lbs. GRIAA.. | \$5.75 |
| No. 3101 | 1/2"x6" 50 grit grade M Wheel, 1/2" hole. Ship. Wt. 1 3/4 lbs. Code GRIAB. | 1.00 |
| No. 3102 | 1/2"x6" 60 grit grade N Wheel, 1/2" hole. Ship. Wt. 1 3/4 lbs. Code GRIAC. | 1.00 |
| No. 3110 | Buffing Head with collars, but without buffing wheels. Shipping Weight: 10 lbs. Code Word GRIAD. | 3.25 |

- Wheels and Brushes for buffing head. 1/2" hole, 6" diameter—Two sections—3/4 lb.**
- | | | |
|-----------------|-------------------------------|---------------|
| No. 3114 | Fine Wire Brush. GRIAH..... | \$1.45 |
| No. 116 | Medium Wire Brush. WIRRO..... | 1.50 |
| No. 3113 | Coarse Wire Brush. GRIAG..... | 1.15 |
| No. 3115 | Fibre Brush. GRIAL..... | 1.20 |
| No. 113 | Buffing Wheel. BUFFO..... | .65 |

MOTOR DRIVEN GRINDER—An Efficient Unit That Cannot Forget Its Goggles

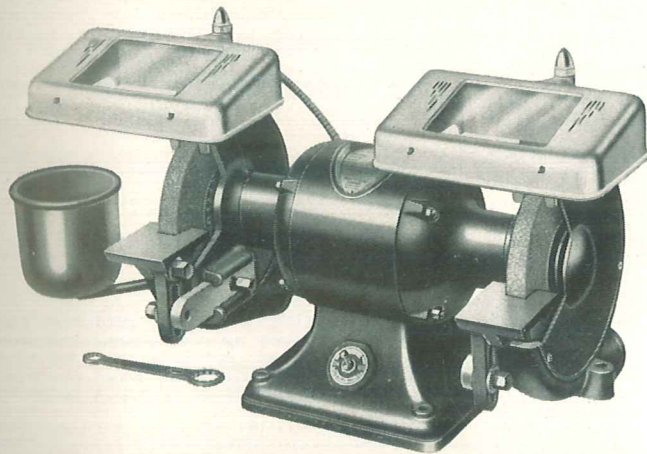

The Finest, Safest and Most Accurate Bench Type Motor Driven Grinder Made

From double-seal ball bearings to Twin-Lite safety-glass shields, these new grinders offer the utmost in efficiency, convenience and safety. New standards of grinder design have been set with this model. Wheels are balanced to within 1/100 inch-ounce to insure vibrationless performance and accurate tool grinding... the Twin-Lite Safety Shields provide perfect vision and complete illumination on both sides and the face of the wheel... ball bearings are lubricated for their entire life... accurate tool supports, adjustable spark guards, swinging water pot—every feature has been considered to make these the most efficient grinders yet developed for all-around work.

You will recognize in them honest value, and tools built for a life-time of trouble-free operation.

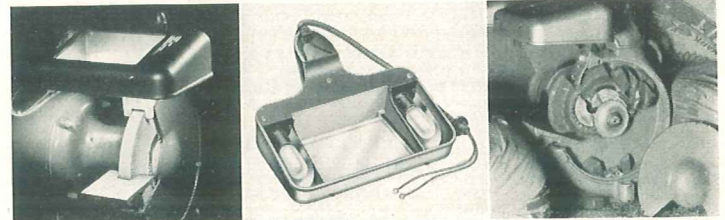

The Safety Twin-Lite guards throw the light down on the face and both sides of the wheel. (Patented.)

Underside of lamp attachment showing bayonet type bulbs—polished reflectors—safe wiring.

Wheel at 8000 R.P.M. smashed with a bullet. Showing perfect safety of grinder—only damage: bent spark guard!

- | | | |
|-----------------|---|----------------|
| No. 1240 | Motor-Driven Bench Grinder, for 110v, A. C. 60 cycle current, complete with 3/4"x7" 60-N and 50-M Aloxite wheels, two Lamp Attachments, Water Pot and Bracket, Tool Rests, Wheel Guards, Toggle Switch, Cord and Plug, without bulbs..... | \$45.90 |
| | Shipping Weight 88 lbs. Code Word GRINA. | |

(For 110v, 60 cyl. Single Phase A. C. only. 3450 R.P.M. unless 1750 is specified.)

- | | | |
|-----------------|--|---------------|
| No. 1245 | 7" Aloxite wheel, balanced within 1/100 oz.-inch, 60 grit, Grade N, 5/8" Hole..... | \$3.25 |
| | Shipping Weight 2 lbs. Code Word GRINJ. | |
| No. 1247 | 7" Aloxite wheel, balanced within 1/100 oz.-inch, 50 grit, Grade M, 5/8" Hole..... | 3.25 |
| | Shipping Weight 2 lbs. Code Word GRINK. | |
| No. 1250 | Lamp Attachment and Safety Shield (one only) with sockets, reflectors and armored cable, but without lamp bulbs.....each | 5.75 |
| | Shipping Weight 3 lbs. Code Word GRILT. | |
| No. 1280 | Lamp Bulb for Safety Shield, each..... | .40 |
| | Shipping Weight 8 oz. Code Word GRILB. | |

For Large Production Pedestal Grinder See the Back Cover.

12-INCH BALL BEARING Lathe Is Accurate, Rigid, Safe, Dependable—Here Is the Best All-Around Lathe For Real Shop Work

Swings 12" Over Bed; 37" Between Centers

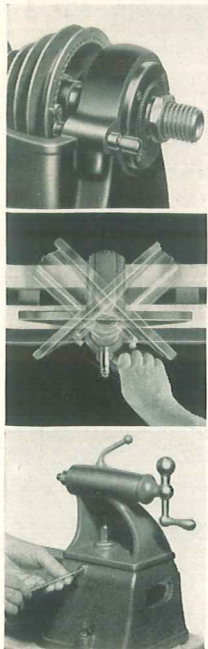

★ **SELF-INDEXING:** Here is the built-in indexing device first applied to lathes by us—made still more convenient.

★ **SELF-LUBRICATING:** New Departure self-sealed ball bearings, which require no lubrication during their entire life, eliminate any need for bearing attention.

★ **UNIVERSAL TOOL SUPPORT:** Quick as a flash in action, solid as a rock in use, locked by a convenient lever on the front of the base—you'll like this support!

★ **4 OR 16 SPEEDS:** Four speeds—all that are necessary for woodturning. But, if you want sixteen speeds, for speed lathe work in metal, a simple countershaft arrangement provides for them.

★ **EFFICIENT DRIVE:** A simple, dependable, V-belt drive—over 90% efficient—provides plenty of power for all your work.

★ **SAFETY HEADSTOCK:** Pulley and belt are completely covered from front and top of lathe—it's practically impossible for fingers to be caught. And belt drive can be taken either from below or rear—an added convenience.

Here is a lathe that was designed with only one purpose in mind—to provide the biggest amount of real lathe for the least amount of money. And when you study the design you will see that it provides just that. No unnecessary frills; no skimping on hidden details; nothing added merely for "looks" and nothing essential omitted for "cheapness".

Designed by engineers with years of experience in making tools for your requirements, built by real mechanics who know and appreciate good machines, it is an honest, solid, dependable lathe for REAL craftsmen—the lathe you want for YOUR shop, whether it is a home shop, a school shop or an industrial shop. See it—try it—and we know you'll agree!

Read the specifications below, and a few of the highlights at the left:

OVERALL DIMENSIONS WITH REGULAR TOOL REST: Length 57". Width 10½", Height 13¾". Width with slide rest 15".

BED: Heavy, substantial, fine-grained cast iron, heavily ribbed to provide utmost rigidity and accuracy. 53½" long, 8½" wide, 4⅞" high. Machined and polished ways 2" wide front and back.

HEADSTOCK: Rigid substantial cast-iron body, adapted to take V-belt drive from either bottom or rear. Fitted with belt guard completely covering top of headstock pulley and belt; guard instantly removable to facilitate

changing belt on pulley cones. With built-in indexing mechanism having two rows of holes—8 holes and 60 holes—in cone pulley, to provide maximum number of index divisions. Index pin mounted to engage either row of holes.

SPINDLE: Full 1½" diameter spindle, with ⅝" hole through center to facilitate repetition work. Nose machined No. 2 Morse taper for centers. Nose threaded 1" diameter 8 threads per inch for chucks and faceplates. Rear end of spindle with 1"—8 thread left-hand thread for outboard work. Spindle carried on two heavy-duty double-seal New Departure ball bearings, pre-loaded to insure maximum rigidity and accuracy. Spindle quickly removable to facilitate belt removal or installation. Speeds: 900, 1400, 2200, 3400 r.p.m.

TAILSTOCK: Substantial, fine-grained cast-iron body, with sub-base and provision for set-over of tailstock for center alignment and taper turning. Tailstock locked to bed with hand lever conveniently located at front. Tailstock sleeve operated with large ball-end crank handle, and locked with ball-end lever actuating lock cams. Sleeve machined for No. 2 Morse-taper centers. Centers self-ejecting.

TOOL REST: Lathe equipped with quick-acting, universal tool-rest base, locked to bed by convenient handle at front of base. 4" and 12" tool rests, adjustable in tool-rest base by means of lock screw with ball-end lever.

ACCESSORIES: 4" and 12" tool rests, 3" faceplate, drive center for wood, tail center for wood, headstock wrench, Allen wrench and belt for lathe-stand installation.

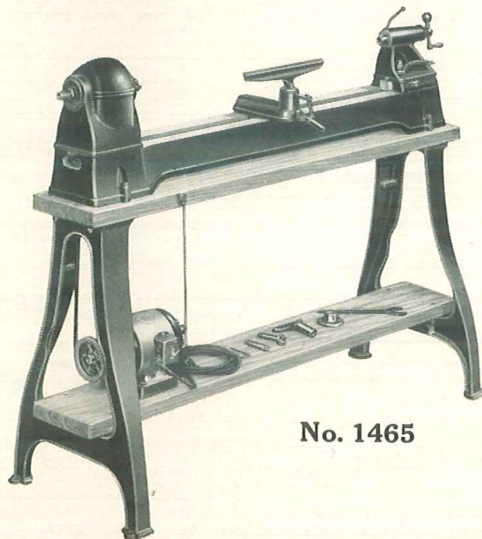

No. 1465

No. 1460 12" Ball-Bearing Lathe, complete with No. 644 belt, 3" faceplate, No. 2 Morse-taper drive and tail centers, 4" and 12" tool supports, spindle wrench, Allen wrench, and tool support base... **\$46.85**
Shipping Weight 135 lbs. Code Word CASTL.

No. 932 4-speed motor pulley, ½" bore... **1.25**
Shipping Weight 2½ lbs. Code Word DUBLC.

No. 1463 Lathe stand only, complete with legs, top, shelf and bolts... **22.85**
Shipping Weight 118 lbs. Code Word CASTP.

No. 1465 12" Four-speed Lathe Unit, including No. 1460 Lathe, No. 1463 Lathe Stand, No. 932 4-speed pulley without motor or switch rod. **\$70.95**
Shipping Weight 253 lbs. Code Word CASTR.
No. 6400 Motor and No. 1334 Switch Rod recommended. See pages 28-30.

11-INCH TIMKEN BEARING Lathe; Long a Favorite With The Home Craftsman Who Wants a GOOD LATHE At a Moderate Price

Swings 11" x 37" Between Centers



Thousands of these lathes are in daily use in shops all over the world... you can't go wrong on this machine!

The No. 930 11" lathe offers exceptional value. It has a rigid, strong steel bed... self-indexing headstock... four speeds from 900 to 3400 r.p.m.... 37" capacity between centers... No. 2 Morse taper centers in head and tailstocks... Timken bearings in headstock for long wear... a full 1 1/4" diameter hollow spindle threaded for inboard and outboard chuck and faceplate work.



No. 950

No. 930	11" Lathe with accessories as shown, less belt and motor pulley	\$29.90
	Shipping Weight 82 lbs. Code Word DUBLA.	
No. 932	Four-step Motor pulley, 1/2" bore	\$1.25
	Shipping Weight 2 lbs. Code Word DUBLC.	
No. 588	V-belt, 25 3/8" cent. to cent.	\$1.10
	Shipping Weight 8 oz. Code Word FORVC.	
No. 950	Four-speed 11" lathe unit, with No. 1463 stand, motor pulley and belt. Without motor or switch rod.	\$55.10
	Shipping Weight 190 lbs. Code Word DUBUN.	

ACCESSORIES For 12 and 11-Inch Lathes and Lathes With No. 2 Morse Taper

No. 933 Drive center for 11" and 12" lathes. Fits any headstock with No. 2 Morse taper hole. Has replaceable center pin and 4 accurately milled teeth **\$1.00**

Shipping Weight 10 oz. Code Word DUBLD.

No. 936 3" faceplate for 11" and 12" lathes. Faced true, has three screw holes. R. H. thread only **\$1.00**

Sh. Wt. 1 lb. Code Word DUBLG.

No. 951 8 1/2" Sanding disk for 11" lathe only. With one garnet disc. R. H. thread only **\$2.25**

Ship. Wt. 2 1/4 lbs. Code Word DUBLM.

No. 934 Cup center for 11" and 12" lathes. Fits any tailstock with No. 2 Morse taper hole. Has replaceable center pin. Hardened and polished **\$.90**

Shipping Weight 10 oz. Code Word DUBLE.

No. 937 6" faceplate for 11" and 12" lathes. Has special thread to fit right hand or left hand threaded spindles **\$2.25**

Sh. Wt. 3 lbs. Code Word DUBLH.

No. 163 3"x3" Sanding drum for 11" and 12" lathes. Fits any headstock with No. 2 Morse taper hole. See page 27 for sanding sleeves **\$2.65**

Ship. Wt. 2 1/2 lbs. Code Word SATAP.

No. 935 Adapter for 11" and 12" lathes. Has No. 2 Morse taper shank on one end—other end 1/2" diameter. Enables use of all attachments with 1/2" bore to be used **\$.85**

Shipping Weight 10 oz. Code Word DUBLE.

No. 938 5" handwheel for 11" and 12" lathes. Left hand thread only. Used by professionals for quick stopping **\$1.95**

Sh. Wt. 1 1/2 lbs. Code DUBLI.

No. 164 1 3/4" x 2" sanding drum for 11" and 12" lathes. Fits any headstock with No. 2 Morse taper hole. See page 27 for sanding sleeves **\$1.95**

Ship. Wt. 1 3/4 lbs. Code Word SATAQ.

No. 940 Screw center for 11" and 12" lathes. Fits any headstock with No. 2 Morse taper hole. Replaceable screw 1 1/2" long **\$1.25**

Shipping Weight 14 oz. Code Word DUBLJ.

No. 948 Steady Rest for 11" lathe **\$3.50**

No. 1468 Steady Rest for 12" lathe **\$3.65**

Ship. Wt. 7 1/2 lbs. Code CASTU. Capacity 2 1/4" dia. Prevents vibration on long and slender work.

No. 968 Geared chuck for 11" and 12" lathes. Fits any headstock or tailstock with No. 2 Morse taper hole. Capacity 1/2". With key... **\$6.95**

Ship. Wt. 2 1/2 lbs. Code Word CHGEA.

No. 165 Wheel arbor for grinding, buffing, wire brushes, etc., with 1/2" hole, 3/4" thick. For 11" and 12" lathes. Fits any headstock with No. 2 Morse taper hole **\$1.25**

Shipping Weight 1 lb. Code Word ARTAP.

No. 941 Tool Support base for 11" lathe only. V-shaped hole for 1/2" to 1" shank. Clamp plate spring, washers, nut included, 3 1/2" high **\$1.10**

Ship. Wt. 4 1/2 lbs. Code Word DUBLK.

No. 166 Keyless chuck for 11" and 12" lathes. Fits any headstock or tailstock with No. 2 Morse taper hole. Holds drills up to 1 1/2". Invaluable for drilling **\$3.40**

Shipping Weight 2 1/2 lbs. Code Word CHTAP.

Screw-on arbor for 11" and 12" lathes. Makes grinder or buffer out of lathe.

No. 144 Right hand **\$1.25**

Sh. Wt. 1 lb. Code Word ARBOS.

No. 145 Left hand **\$1.25**

Ship. Wt. 1 lb. Code Word ARBOT.

No. 1461 Tool Support base for 12" lathe only. V-shaped hole for 1/2" to 1" shank. Clamp plate spring, washers, nut included, 3 1/2" high **\$3.30**

Ship. Wt. 5 lbs. Code Word CASTM.

Note
Additional attachments which are used on all lathes listed on page 38 (lower). See page 27 for other sanding drums.

9-IN. TIMKEN BEARING LATHE Offers Real Value Consistent With Price

The 9" lathe offers real value to the man who wants to equip his shop at the lowest cost consistent with the purchase of quality tools. Built to the same standards of accuracy and construction as the 11" lathe, the No. 955 offers husky Timken tapered-



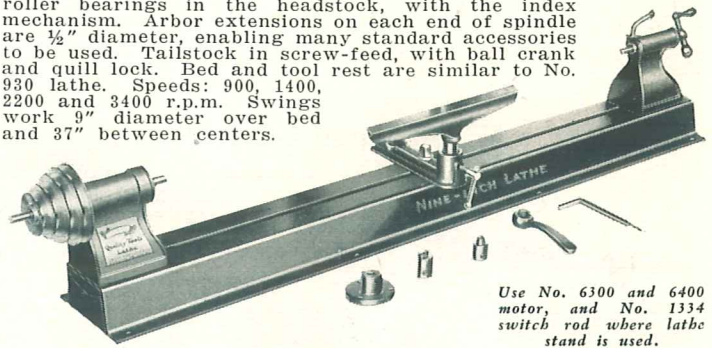





roller bearings in the headstock, with the index mechanism. Arbor extensions on each end of spindle are 1/2" diameter, enabling many standard accessories to be used. Tailstock in screw-feed, with ball crank and quill lock. Bed and tool rest are similar to No. 930 lathe. Speeds: 900, 1400, 2200 and 3400 r.p.m. Swings work 9" diameter over bed and 37" between centers.



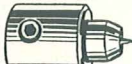





Use No. 6300 and 6400 motor, and No. 1334 switch rod where lathe stand is used.

- No. 955** 9-inch Four-Speed Timken Bearing Lathe, including 3" faceplate, spur center, cup center, 12" tool-support, tool-support wrench and special Allen wrench, as shown, 4" tool support and tool support base **\$19.85**
Shipping Weight 70 lbs. Code Word NEWLA.
- No. 932** Four-speed Motor Pulley (1/2" Bore)..... **\$1.25**
Shipping Weight 3 lbs. Code Word DUBLCL.
- No. 568** V-belt, 24 1/2" center to center..... **\$1.00**
Shipping Weight 10 oz. Code Word FORVD.
- No. 960** 9-inch Four-Speed Lathe Unit, including No. 955 Lathe, No. 1463 Lathe Stand, No. 932 four speed pulley 1/2" Bore and No. 568 V-belt, similar to No. 950 unit shown on page 37 **\$44.95**
Shipping Weight 185 lbs. Code Word NEWUN.

ACCESSORIES FOR 9-INCH LATHE ONLY OR LATHE WITH 1/2-INCH ARBOR EXTENSIONS

Sh. Wt. 8 oz.  Code SPURO No. 138 Drive center for 1/2" spindle. Replaceable center-form milled teeth... \$.80	Sh. Wt. 12 oz.  Code SCREO No. 140 Screw center for 1/2" spindle. 1 1/2" dia. body. Excellent for small work. \$.80	Sh. Wt. 8 oz.  Code CUPPO No. 141 Cup center for 1/2" tailstock. Replaceable center. Hardened, well-made \$.70	Sh. Wt. 1 lb.  Code ARBOR No. 118 Arbor for grinding wheels, buffers, etc., 1/2" hole for 1/2" spindle \$.85	Sh. Wt. 1 1/2 lbs.  Code CHUKO No. 120 Keyless chuck. Capacity 33/64". Fits any 1/2" shaft. Accurate, high grade \$1.75
 No. 151 8 1/2" dia. Sanding disk. 1/2" bore. With one garnet disc. Ship. Wt. 2 1/4 lbs. Code DISSA \$2.10	Sh. Wt. 14 oz.  Code FACEO No. 143 3" face plate. Fits any 1/2" shaft. Has two Allen set screws, four holes for wood screws.... \$.75	 No. 696 Tool rest base. V-hole for 1/2" to 1" shank. Spring, washer, bolt, nut. Ship. Wt. 4 lbs. Code TOSUB \$1.10	Sh. Wt. 8 oz.  Code AWREN No. 192 Allen wrench for 3/8" Allen set screws. 6" long. Especially useful in tightening cone pulleys \$.25	 No. 958 Steady rest. 9" lathe only. Prevents vibration in long and thin turnings. Complete. Sh. Wt. 6 lbs. \$3.50 lbs.. Code NEWRS

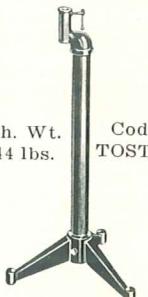
ALL LATHES In This Catalog Can Use The Accessories Listed Here

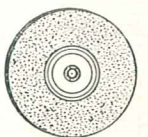
 No. 690 4" tool rest. 1" dia. shank. Very strong and heavy. Sh. Wt. 1 1/4 lbs. Code TOSUP . \$.75	 No. 692 12" tool rest. 1" dia. shank. Heavy, strong, designed for minimum interference with tools and hands \$1.10 Sh. Wt. 3 lbs. TOSUM .	 No. 695 Right-angle tool rest. 1" dia. shank. Extremely useful for face-plate work... 1.50 Sh. Wt. 3 lbs. TOSRA .	 No. 694 24" tool rest for extra long turnings. Has two 1" dia. shanks. This rest requires an extra tool rest base for the lathe on which it is used \$2.15 Sh. Wt. 7 lbs. Code TOSUL .	 Sh. Wt. 44 lbs. Code TOSTA . No. 697 Heavy, rigid floor stand for faceplate work on left of spindle. Tripod legs, pipe support. V-hole for 1/2" to 1" shank. Knocked down \$8.50
Wire and fibre brushes for cleaning metal, removing burrs. Well made, two sections. 6" dia., 1/2" hole. No. 3114 Wire, fine. GRIAH \$1.45 No. 116 Wire, medium. WIRRO 1.50 No. 3113 Wire, coarse. GRIAG 1.15 No. 3115 Tampico fibre. GRIAI 1.20 Shipping Weight 1 lb. each.	 No. 113 6" dia. two Section buffing wheel. 1/2" hole. Sh. Wt. 8 oz. Code BUFFO . \$.65	 6" dia. high grade fast cutting emery wheels. 1/2" wide, 1/2" hole. No. 3101 50 Grit. GRIAB \$1.00 No. 3102 60 grit. GRIAC \$1.00 Sh. Wt. 1 1/4 lbs. ea.		

ALLOY-STEEL WOODTURNING TOOLS

Our wood-turning tools are made of very high-grade Alloy Steel, which will not lose its edge even if the tools become so hot that they turn blue. They are sharpened ready for use. They are fitted with extra-long hardwood handles (1 1/4" diameter x 10 1/2" long). The overall length of each tool is approximately 15". They should not be confused with ordinary carbon-steel tools, as they are superior in every way. Shipping Weight 1 1/4 lbs. each.

- No. 121** 1" Skew Chisel. Code Word **SKERE** **\$1.35**
- No. 122** 3/4" Gouge. Code Word **GOUGU** **1.35**
- No. 123** 1/2" Gouge. Code Word **GOUSA** **.90**
- No. 124** 1/2" Skew Chisel. Code Word **SKEWO** **.80**
- No. 125** 3/8" Parting Tool. Code Word **PARTO** **\$.80**
- No. 126** 1/2" Gouge. Code Word **GOUGO** **1.00**
- No. 127** 1/2" Spear Point. Code Word **SPEAR** **.80**
- No. 128** 1/2" Round-Nose. Code Word **RONOS** **.85**
- No. 130** Set of Eight Turning Tools, styles and sizes as above **7.50**
Shipping Weight 6 lbs. Code Word **TOSSET**.

BENCH LEGS

Take all the grief and hard work out of building a substantial bench. Strongly made and beautifully designed of welded steel, these legs should not be confused with cheap bolted bench legs which will not make a rigid bench. With these, all that is needed for a perfect bench is three 2" planks, 9 1/2" wide, of good select stock. Bolt them to the legs and you have a bench that will astonish you with its rigidity. Shelf and top heights suit all our standard belt lengths.

- No. 344** Steel bench leg only, as shown, Each **\$3.25**
Shipping Weight 21 1/2 lbs. Code Word **LEGSO**.

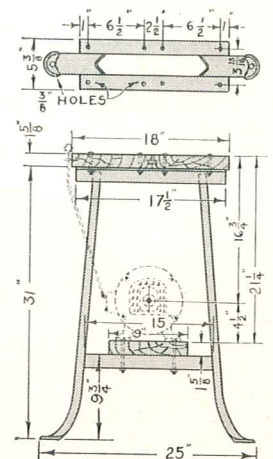

METAL TURNING Is Simple and Profitable With This Equipment

16-SPEED METAL WORKING LATHES

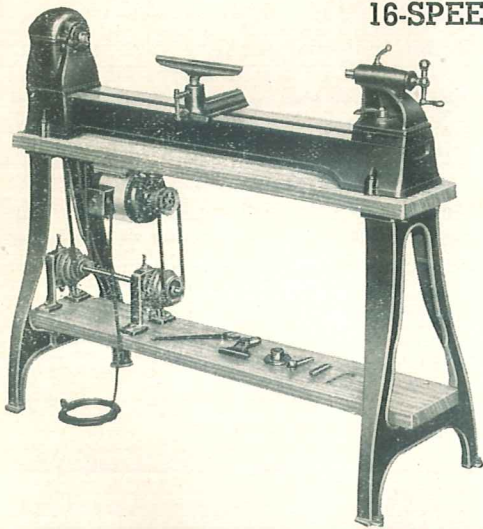

The addition of a countershaft unit (as illustrated) to the 11-inch and 12-inch lathes turns these units into efficient and accurate 16-speed lathes for metal working. The slower speeds can be used for large face plate wood turning. The addition of the slide rest gives you a practical machine for light metal work. Practically everything in lathe work with the exception of screw cutting can be done. Speeds range from 350 to 3160 R.P.M. For 11 and 12-inch lathes. Illustration shows 12-in. lathe—11-in. lathe is similar in appearance.

No. 1466 12" 16 speed lathe (illustrated) with No. 1460 lathe, No. 1463 stand, No. 1464 countershaft unit. Without motor or switch rod..... **\$79.85**
Shipping Weight 278 lbs. Code Word CASTS.

No. 952-A 11" lathe 16 speed unit, with No. 930 lathe, No. 1463 stand, No. 1464 countershaft and No. 588 belt. Without motor or switch rod..... **\$64.00**
Shipping Weight 225 lbs. Code Word DUBUT.

No. 1464 Countershaft unit, consisting of two No. 370 hangers, 1 No. 378 shaft, 1 No. 718 pulley, 1/2" bore for motor, 1 No. 720 pulley, 3/4" bore for shaft, 1 No. 932 pulley, 3/4" bore for shaft, 1 No. 284 V-belt, 2 No. 374 collars, bolts and nuts..... **\$10.15**
Shipping Weight 25 lbs. Code Word CASTQ.

COMPOUND SLIDE REST ENABLES YOU TO DO MANY OPERATIONS

No. 965 Compound slide rest for 11" lathe. Without toolholder or tools **\$19.50**

Sh. Wt. 35 lbs. Code Word DURST

No. 1462 Compound slide rest for 12" lathe, same as No. 965, but with sub-base. Without alignment bar **\$20.85**

Sh. Wt. 38 lbs. Code Word CASTO

No. 1467 Sub-base, clamp and bolts only; to convert No. 965 slide rest into No. 1462... **\$2.30**

Sh. Wt. 5 lbs. Code Word CASTT

This slide rest is a high-grade accessory, heavily and accurately built, with dovetail slides and a graduated compound base rotating through 360 degrees. Feed screws are covered to protect them from dirt and chips, and are fitted with micrometer sleeves, accurately graduated. Alignment bar on front of 11" lathe model can be set for permanent alignment with centers. This is a high-grade slide rest at a reasonable price.

Should be used only with No. 952-A or No. 1466 sixteen-speed units, or other lathes with 9" to 12" swing and with speeds low enough for metal turning.

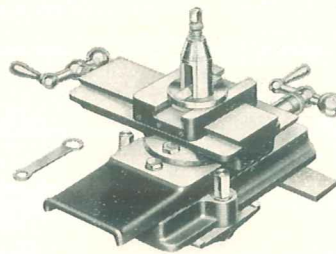

BORING BARS & HOLDER

Holds both bars and square 1/4" bits. Two holes in holder facilitate holding of tool. Tool steel, case hardened.

No. 962 Boring-bar holder, with 1/4" bars 3/8", 1/2" and 3/4" **\$3.00**
Ship. Wt. 12 oz. Code Word DUBBO.

No. 966 Set of three boring bars, 1/8", 1/4" and 3/8" **\$1.15**
Ship. Wt. 8 oz. Code Word DUBOR.



UNIVERSAL CHUCK FITS EVERY NEED OF THE SMALL LATHE

No. 963 Three-Jaw Universal Chuck, with inside and outside hardened-steel jaws, and wrench. Without back plate **\$13.85**

Sh. Wt. 6 lbs. Code Word CHUNP.

No. 963-A Back plate for No. 963, turned and threaded to fit spindle of No. 930 and 1460 lathes, but not fitted to chuck... **1.75**

Sh. Wt. 2 lbs. Code Word CHUPI

No. 964 Back plate for No. 963 and 943-A, completely unfinished. For lathes of other make. **.70**

Sh. Wt. 2 lbs. Code Word CHUPL

High-grade self-centering universal chuck, with heavy cast-iron body and two sets of hardened-steel jaws, adaptable for either 11" or 12" lathes. For use with No. 930 or 1460 lathes, order chuck with No. 963-A back plate. For use with other lathes order back plate No. 564. Back plates must be turned to fit chuck while mounted on lathe on which they are to be used, in order to insure accuracy. Diameter of chuck, 4". Maximum capacity, 4".

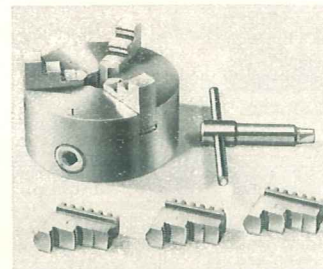

Independent Chuck

No. 943-A 4-Jaw Independent Chuck. Very heavy cast-iron body with hardened steel jaws. Chuck diameter 4". Maximum capacity 4 1/2". Each jaw independently adjustable. Without back plate. **\$7.95**
Sh. Wt. 5 lbs. Code Word DUCHO..

No. 943-B Back plate for No. 943-A chuck, machined to fit No. 930 & 1460 lathes. **\$1.50**
Sh. Wt. 2 lbs. Code Word DUCHL..

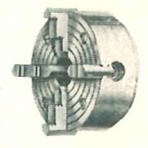

Metal Spinning Tool Rest

Movable pin and holes in top of rest facilitate placing of spinning tool for proper leverage. Exceptionally heavy, rigid, 1" shank.

No. 1491 Tool rest for metal spinning **\$2.25**
Sh. Wt. 4 lbs. Code Word SPINB.

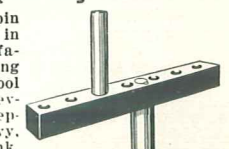

New TOOLS FOR METAL SPINNING

These fine metal spinning tools are heavy and strong so that the spinning metal may be forced over the form with ease and safety. Made in four different styles, each with handle, they fill the requirement for all ordinary work.

No. 1492 Flat Tool. SPINC **\$2.65**

No. 1493 Point Tool. SPIND **2.65**

No. 1494 Cut-off Tool. SPINE **2.65**

No. 1495 Reading Tool. SPINF **3.85**

Shipping Weight 2 1/2 lbs. each.

No. 1496 Set of Four Tools. SPING. **\$11.80**

Shipping Weight 9 lbs.

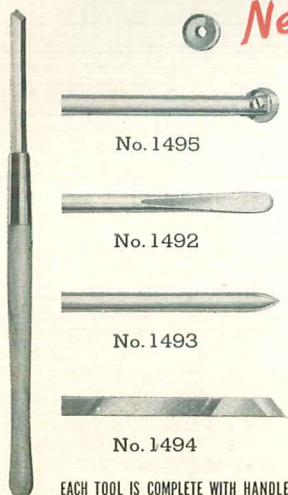

EACH TOOL IS COMPLETE WITH HANDLE

BALL-BEARING CENTER

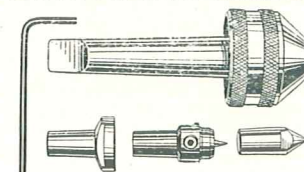

Fitted with 60° center, cup center (pin may be removed) and flat center. Used for clamping follow block in metal spinning.

No. 1490 Complete as illustrated ... **\$5.35**
Sh. Wt. 1 1/2 lbs. Code Word SPINA.

PLAIN 60° CENTER



No. 939 60° plain center with No. 2 Morse taper shank used for metal turning. Hardened and ground. **\$1.00**
Sh. Wt. 12 oz. Code Word DUBLO.

FEET FOR YOUR LATHE

Used only for metal turning, to permit the chips to drop clear of the Bed

No. 961 Set for four Lathe Feet..... **\$1.95**
Sh. Wt. 9 lbs. Code Word DUBFE.

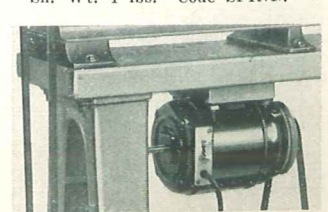

MAKE SURE That The Drill Press You Purchase Has Both a **SELF-ALIGNING Drive** And a **FREE-FLOATING Spindle**

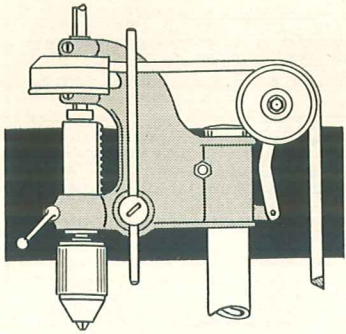

The first successful ball-bearing drill press in the small-tool field was our No. 620 drill press shown at the left. This was a four-bearing drill press. One ball bearing was used above the spindle pulley and one below. Two ball bearings were used to carry the spindle in the quill. Since in this design none of the belt pull was transmitted to the spindle, we called this type of drive "free-floating".

Our engineers soon found that this type of design, while excellent for its original purpose, had certain decided limitations. In the course of years of experiment and study incidental to the introduction of 14" sensitive

drills for industrial use (in which we were the pioneers), we tested dozens of different ball-bearing combinations in dozens of different designs—and finally evolved the present patented three-bearing design used in our 14" drill presses.

Our exceptionally wide experience has convinced us that this three-bearing design is far superior to any four-bearing drill press using the type of design that we formerly used on our now-obsolete No. 620 drill press. And the experience of thousands of users bears out our own experience.

Only Our Patented Design Gives You **BOTH** of These Features!

With the latest and most modern machine equipment, including "diamond-boring" machines as used in our shops, it is an easy matter to bore drill-press bearing housings, quill seats, etc., to close tolerances. But the design of a high-speed telescoping drill-press spindle drive requires more than precision machining—it requires a design that will stay in alignment. And there are a number of factors that make this problem more difficult than it looks.

First, the comparatively long range of telescoping of the spindle and quill; second, the high speed at which the spindle rotates; third, the fact that the quill and spindle must be locked or clamped in various locations; fourth, the fact that the spindle is often subjected to severe side thrusts, and so

on. When all these factors are considered, it is obvious that the slightest variation in alignment is likely to produce difficulties.

The mis-alignment encountered in service may be small—perhaps not more than .002"—but we consider that even this slight amount is sufficient to cause trouble in high-speed spindles, and it is this trouble that our patented type of drive is designed to prevent.

In a four-bearing drill press similar to our now obsolete No. 620 machine, you may have a so-called "free-floating" design, in which the belt pull is not transmitted to the spindle. But you do NOT have the self-aligning features of our improved drive (designed to overcome the troubles of the four-bearing type) because these features are patented.

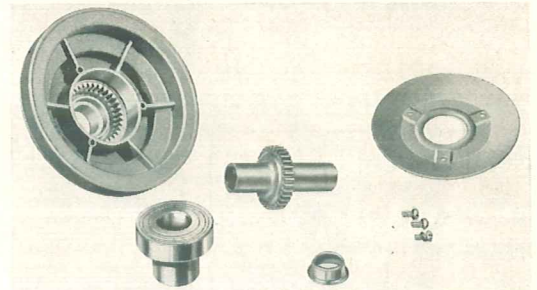

This photo shows the drive pulley with its internal gear, the floating sleeve with its spur gear, the huge ball bearing that carries the pulley and the lower pulley cover plate.

How the floating sleeve is engaged with the internal gear in the pulley is shown in the first photo. This forms a clutch which permits the sleeve to float in all directions but one.

The floating sleeve engaged with the pulley. This forms a positive driving medium for the spindle, but at the same time takes up any minute variations in alignment that may occur in service.

The pulley is carried on a large sealed-for-life ball bearing, requiring no lubrication, and with a load capacity far in excess of any pulley ever placed on it by the belt.

There is no power-wasting fan action in this pulley, because the plate that secures the bearing in place also completely covers the pulley ribs—the final detail of a high-grade design.

The Spindle Drive **STAYS** Aligned!

From the outside, our driving pulley looks like any other simple pulley. But, as the photos show, it is actually radically different. The pulley itself is carried on a huge sealed-for-life ball bearing, of special deep-groove tight-fitting design, with enormous reserve capacity above that required to take the belt pull, and requiring no lubrication or other attention. This bearing is mounted by means of a special extension of the inner race so that it cannot be sprung. This is very important.

The actual drive of the pulley is transmitted to the spindle through a floating sleeve, with spur-gear teeth cut around its hub. These teeth mesh with an internal gear in the pulley so that the sleeve can "float" in all directions except the driving direction. This floating sleeve drives the spindle through splines fully 3 1/4" long.

The underside of the pulley is covered with a heavy pressed-steel plate, which not only secures the bearing in the pulley, but which also covers the pulley ribs and prevents power-wasting "fan action" and keeps out dirt when the drill head is operated upside-down.

Study the action of the floating sleeve and you will see that you not only get a true "free-floating" drive, but that you also get complete freedom from misalignment troubles due to wear or any other service conditions. This drive stays aligned.

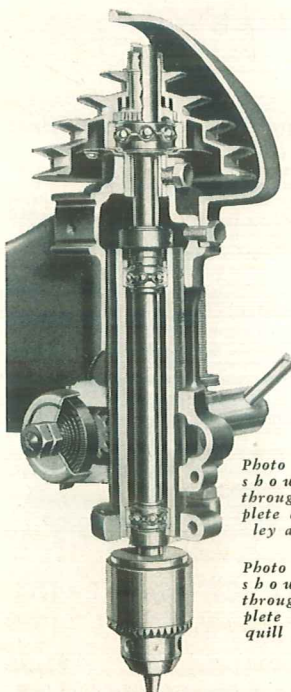
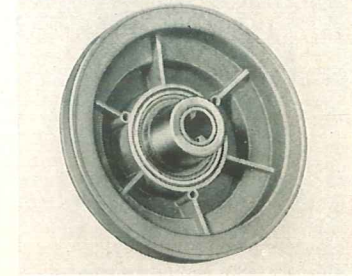
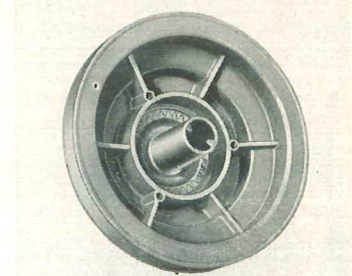
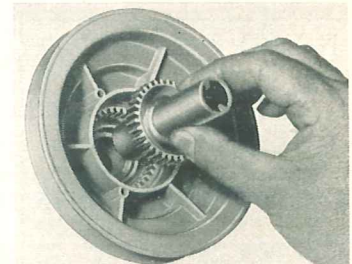
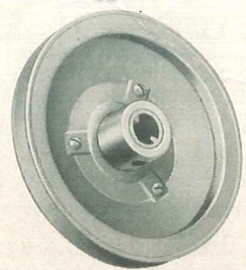
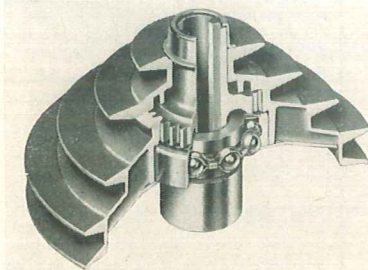

Photo at right shows section through complete drive-pulley assembly.

Photo at left shows section through complete drive and quill assembly.



THE FINEST Small Drill Press Ever Offered The Craftsman

The owner of the small shop who does not require the capacity of a large machine, yet who wants the highest quality in his tools will find in the No. 645 drill press the answer to all his requirements.

It will, of course, perform all the drilling in metal that is to be done around the shop—and it takes drills up to $\frac{3}{8}$ " in diameter. In addition to this, it will take all standard wood bits with $\frac{1}{2}$ " shanks, and can be used for boring holes up to 2" in diameter with standard multi-spur bits.

With the addition of the No. 976 mortising attachment, it becomes an efficient mortising machine, making square-end mortises from $\frac{1}{4}$ " to $\frac{1}{2}$ " width, and of any length, with ease and speed.

Standard router bits with $\frac{1}{2}$ " shanks are held in the No. 974 router spindle, and permit much intricate work to be done which would otherwise take hours of tedious hand labor. Expert craftsmen find numerous uses for this feature.

Sanding, too, is done with the utmost facility, using the No. 835 or 840 drum sanders, rigidly held in the No. 974 spindle. These sanders smooth the edges of straight and curved work with a quickness and sureness that is a revelation to those accustomed only to the tediousness of hand finishing.

And many craftsmen whose hobbies include metal working, will find

that the accurate construction and convenient adjustments of this drill press enable it to be used for many jobs of surface grinding, using a No. 992 cup wheel on the No. 991 spindle.

All of the spindles used for the No. 970 drill press may be used on this machine also. The standard machine is fitted with a high-grade keyless chuck of our own design, thousands of which are giving every satisfaction to craftsmen everywhere.

Study the features of this machine; its massive design, its precision construction, the tilting table with its locating pin, the graduated quill and adjustable pointer for depth boring and drilling, the stop rod and nuts for repetition drilling. Study the floating spindle pulley (originally developed by us) that eliminates belt pull and strain on the spindle—the self-sealed New Departure ball bearings used throughout, and which require no lubrication during their entire life, and you will see why we say that this is the ideal machine for the small shop—ideal for the craftsman who demands the best even in a smaller machine.

Specifications

Overall dimensions with motor: $34\frac{1}{2}$ " high, $11\frac{3}{4}$ " wide, 19" front to back. 8" x 8" slotted, finely machined cast-iron table. $6\frac{1}{4}$ " x $7\frac{1}{2}$ " table surface on base.

Maximum distance, chuck to table $10\frac{7}{8}$ "; chuck to base 14". Spindle travel, 4". Column diameter, $1\frac{7}{8}$ ". Chuck capacity $\frac{3}{8}$ ". Drills to center of 11" circle.

Full-floating, automatically aligned spindle pulley. "Sealed-for-life" ball bearings throughout; lubricated for life of bearings.

Graduated quill. Adjustable depth pointer. Stop rod and knurled nuts. Tilting table with index pin.

All interchangeable spindles for 14" drill press can be used on this machine.

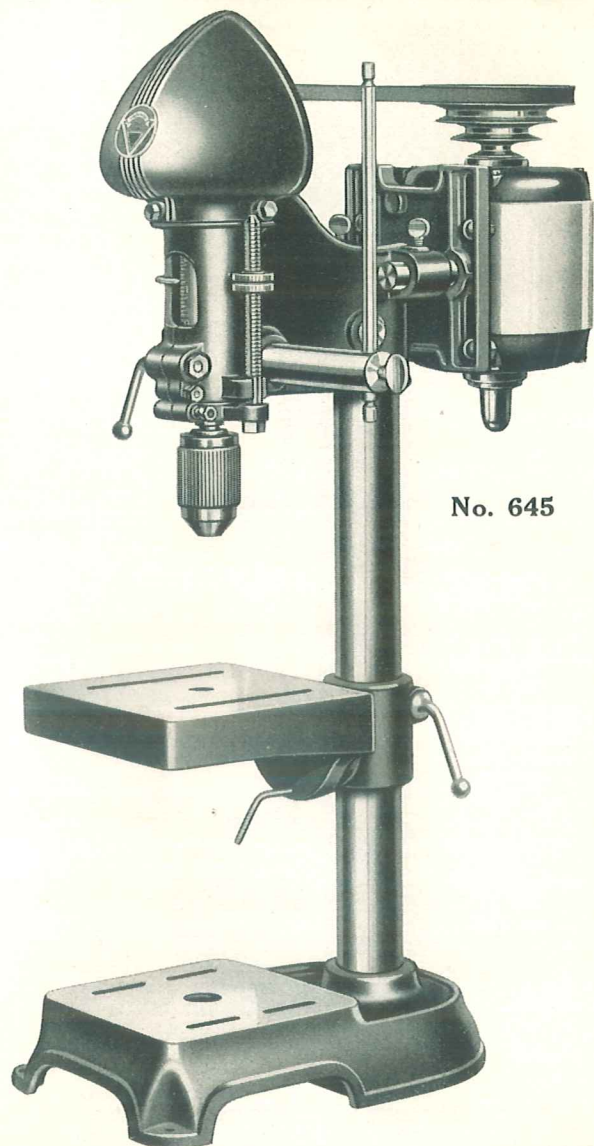

No. 645

No. 645 11" Bench-model Drill Press, with No. 340 V-belt and No. 985 V-pulley, $\frac{1}{2}$ " bore, but without motor. **\$25.95**
Shipping Weight 83 lbs. Code Word PRENU.

No. 340 Extra V-belt for above, 13" center to center **\$.80**
Shipping Weight 8 oz. Code Word BELUX.
No. 6400 motor recommended. See pages 28-30 for price.

No. 992 $3\frac{1}{2}$ " x $1\frac{1}{2}$ " cup wheel for use with No. 991 spindle on all 11" and 14" drill presses (See Pg. 42)..... **\$2.25**
Shipping Weight $1\frac{1}{2}$ lbs. Code Word NEWCU.

SEE BACK COVER FOR 17 INCH DRILL PRESS

See How **Versatile** This Machine Is for the Small Shop!

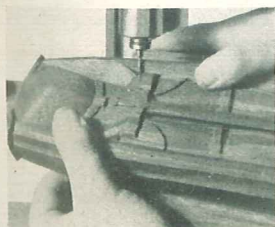

Using small carving bits for carving in the round saves hours of patient labor for the carver.

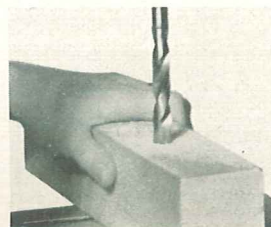

Boring in wood with spur bits is practical because of the standard high speed.

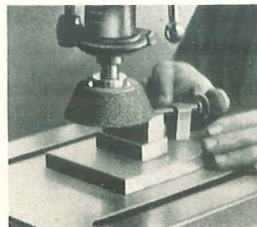

Surface grinding is one of the unusual jobs for which this modern tool is adapted.

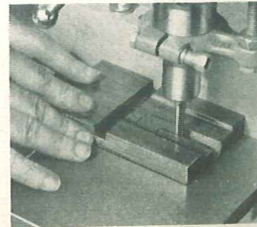

The routing of all kinds of grooves is made absurdly simple, using standard router bits.

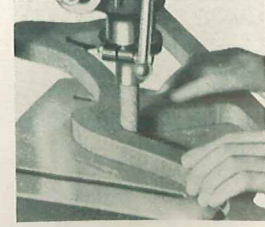

Sanding the edges of carved work with the sanding drum saves hours of tedious labor.

14-INCH DRILL PRESSES Will Save Time and Money in Your Shop

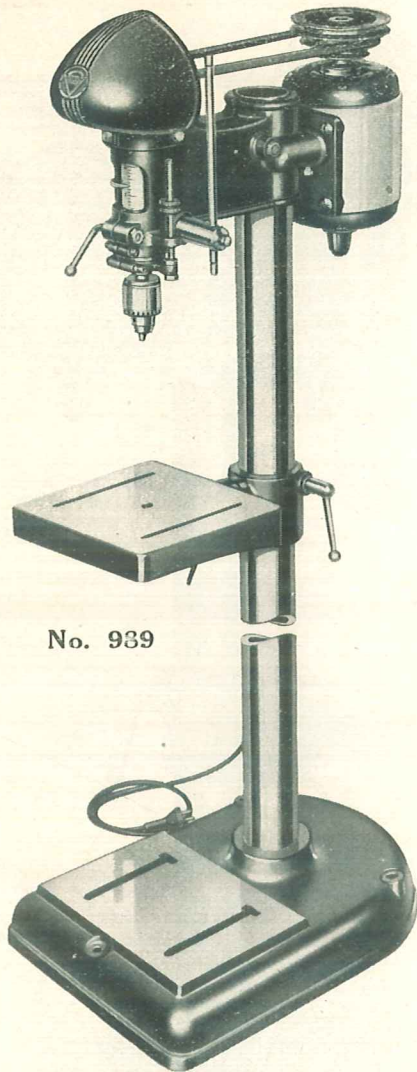

No. 939

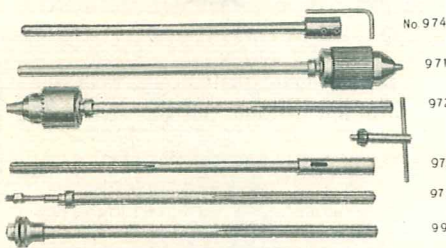

There are many reasons why this drill press is the one that you should buy for all drilling up to $\frac{1}{2}$ " in metal, whether it is to be used for industrial, school or home shop. The experience gained during our development of drill presses of this type for industrial purposes insures that it is the finest machine of its kind you can buy.

For industrial use, the advantages of low initial investment, plus very low maintenance and power cost, are so obvious that thousands of industrial shops use these tools for these reasons alone. But there are additional advantages that make them the ideal machines for production use. They are completely portable, so that they require no installation expense and can be set anywhere in the shop to suit changing production conditions. They can be used to supply additional spindles on multi-spindle machines. They can be set up alongside other machines so as to employ the

operator's idle time. They can be used to make up complete, self-contained drilling units which actually cost less than conventional jigs. The heads can be used to make up special drilling units at a fraction of the cost of special machines for the same job.

In the school shop, they offer the same advantages of low first cost, low maintenance and power cost, portability and adaptability. They can be used for drilling and boring in metal or wood, for shaping, routing, surface grinding, mortising and sanding, and the design of the interchangeable spindles insures minimum overhang under the quill bearings, and thus better work.

For the home shop, the fact that thousands of these machines are used in industrial and school shops is evidence that they offer maximum value. And its versatility—the dozens of jobs that can be done on it—makes this drill press a favorite with all craftsmen who know good tools.

"Sealed-for-Life" Bearings Eliminate Lubrication

No lubrication is ever required on these drill presses. The New Departure bearings used throughout are lubricated and sealed at the factory, and require no further attention during their entire life. Both floor and bench-type machines are equipped with Jacobs' geared chucks of full No. 60 to $\frac{1}{2}$ " capacity. These should not be confused with lighter chucks of from $\frac{1}{8}$ " to $\frac{1}{2}$ " capacity. All chucks are balanced for high-speed work. Spindles have deep double splines which insure proper balance and long wear due to their wide area of contact.

Condensed Specifications

Overall height:
 Floor model...68" Bench model...36 $\frac{1}{2}$ "
 Column diameter, both models.....2 $\frac{3}{4}$ "
 Table travel:
 Floor model...43" Bench model...11 $\frac{1}{2}$ "
 Spindle travel, both models..... 4"
 Drills to center of 14" circle.
 Max. Distance, table to spindle:
 Floor model...41 $\frac{3}{4}$ " Bench model...11 $\frac{1}{2}$ "
 Chuck to base:
 Floor model...47" Bench model...17"
 Table size, both models, 10" x 10"

Special Spindles

- | | | |
|---------|---|--------|
| No. 974 | With $\frac{1}{2}$ " hole for router bits, etc. Sh. Wt. 2 $\frac{1}{2}$ lbs. NESP.D. | \$2.20 |
| No. 971 | With Keyless Chuck, cap. 0- $\frac{1}{4}$ " Sh. Wt. 3 $\frac{1}{2}$ lbs. Code NESP.A. | 3.45 |
| No. 972 | With Jacobs Chuck, cap. No. 60- $\frac{1}{2}$ ". Sh. Wt. 3 $\frac{1}{2}$ lbs. NESP.B. | 6.95 |
| No. 973 | With No. 1 Morse-Taper hole Sh. Wt. 2 lbs. Code NES.P.C. | 3.45 |
| No. 977 | For $\frac{3}{8}$ " hole shaper cutters. Sh. Wt. 2 lbs. Code NES.P.F. | 1.95 |
| No. 991 | For cup wheels Sh. Wt. 2 lbs. Code NES.P.G. | 2.20 |

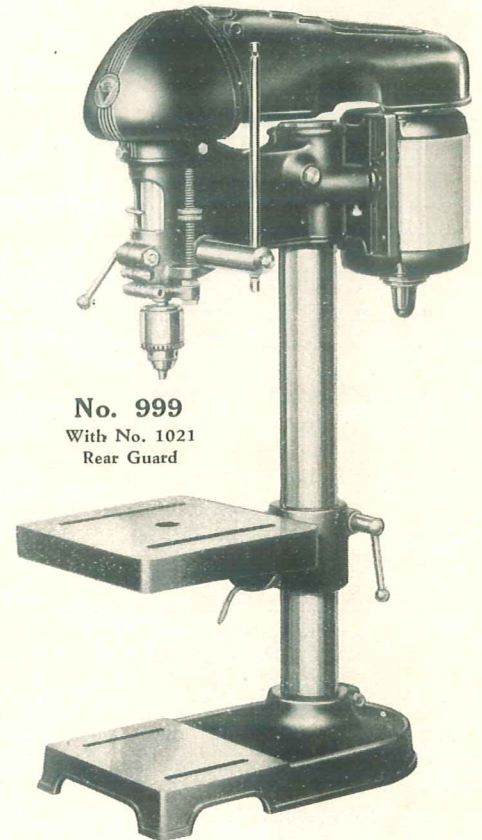

No. 999
With No. 1021
Rear Guard

FLOOR-TYPE 14" DRILL PRESSES

High-Speed Models

590, 1275, 2450 and 5000 R.P.M.

No. 989 Floor-type, High Speed, 14" Drill Press, with $\frac{1}{2}$ " Jacobs geared chuck, No. 387 V-belt and No. 985 motor pulley. Without motor or switch rod... **\$41.85**
 Shipping Weight 145 lbs. Code Word NEWJ.C.

No. 970 Same as No. 989 but with No. 971 Keyless Chuck... **\$38.35**
 Shipping Weight 145 lbs. Code Word NEWD.P.

Slo-Speed Models

390, 745, 1280 and 2050 R.P.M.

No. 1286 Floor-Type, Slo-Speed Drill Press, as above, but with No. 1 Morse Taper Spindle (without motor) Shipping Weight 147 lbs. Code Word SLO.F.B.

No. 1289 Same as No. 1286, but with $\frac{1}{2}$ " capacity geared chuck and spindle (without motor)... **\$43.55**
 Shipping Weight 149 lbs. Code Word SLO.F.C.

No. 1270 Same as No. 1286, but with keyless chuck (without motor) Shipping Weight 149 lbs. Code Word SLO.F.A.

ACCESSORIES

- | | | |
|-----------------|---|--------|
| No. 387 | Extra Belts Sh. Wt. 1 lb. Code FORD.P. | \$.85 |
| No. 985 | Motor Pulley, $\frac{1}{2}$ " bore... Sh. Wt. 2 $\frac{1}{2}$ lbs. NEW.P.U. | 1.30 |
| No. 1331 | Switch rod for all 11" and 14" drill presses, with loop. To fit new style motors Shipping Weight 1 $\frac{1}{2}$ lbs. Code Word ROD.N.B. | .45 |
| No. 1010 | Collar for drill-press column (2 $\frac{3}{4}$ " Diam)..... Shipping Weight 1 lb. Code Word NES.C.C. | .60 |
| No. 1021 | Cast Aluminum Guard for 14" High Speed Drill Press Shipping Weight 13 lbs. Code Word PRO.D.G. | 8.75 |
| No. 1022 | Cast Aluminum Guard for 14" Slo-Speed Drill Press. Shipping Weight 17 lbs. Code Word PRO.D.I.I. This type of guard is shown on No. 999 Drill Press. | 9.75 |

Use No. 6300, 6400 or 6500 motor. Switch Rod No. 1331. See pages 28-30.

SEE BACK COVER FOR 17 INCH DRILL PRESS

BENCH-TYPE 14" DRILL PRESSES

High-Speed Models

590, 1275, 2450 and 5030 R.P.M.

No. 999 Bench-type, High Speed, 14" Drill Press, with $\frac{1}{2}$ " Jacobs geared chuck, No. 387 V-belt and No. 985 motor pulley. Without motor, switch rod or rear belt guard. Sh. Wt. 110 lbs. Code BEN.J.C. **\$35.95**

No. 995 Same as No. 999 but with No. 971 Keyless Chuck... **\$32.45**
 Shipping Weight 110 lbs. Code Word NEWB.E.

Slo-Speed Models

390, 745, 1280 and 2050 R.P.M.

No. 1300 Bench-Type Slo-Speed Drill Press, as above, but with No. 1 Morse Taper Spindle (without motor) Sh. Wt. 101 lbs. Code Word SLO.B.F. **\$34.15**

No. 1302 Same as No. 1300, but with $\frac{1}{2}$ " capacity geared chuck and spindle (without motor) **\$38.55**
 Shipping Weight 102 lbs. Code Word SLO.B.G.

No. 1295 Same as No. 1300, but with keyless chuck (without motor). Sh. Wt. 102 lbs. Code SLO.B.E. **\$34.15**

ACCESSORIES For Drill Presses Increase Use Of The Machine

HOLLOW CHISELS AND BITS FOR MORTISING



Produce square-end mortises. Made of selected steel, suitable for the highest grade of work. The bit operates inside the chisel, is driven by the drill-press or mortiser spindle, while the chisel is held stationary by means of a chisel holder. When used in the 11" and 14" drill press, No. 974 spindle must be used, each bit should be ordered with its proper bushing.

Standard Hollow Chisels

Outside diameter of bushings is $\frac{1}{8}$ ". Shank of chisel $\frac{5}{8}$ " x $1\frac{1}{2}$ ". Shipping weight per set, $1\frac{1}{4}$ lbs.

No.	Size	Depth of Mor.	Code	Price
504	$\frac{1}{4}$ " x $\frac{1}{4}$ "	$1\frac{1}{8}$ "	CHISA	\$4.30
505	$\frac{3}{8}$ " x $\frac{3}{8}$ "	$1\frac{1}{8}$ "	CHISB	4.30
506	$\frac{3}{8}$ " x $\frac{3}{8}$ "	$2\frac{3}{4}$ "	CHISC	5.25
508	$\frac{1}{2}$ " x $\frac{1}{2}$ "	$3\frac{1}{4}$ "	CHISE	5.95

Bushings

No.	Size	Code	Price
524	$\frac{3}{16}$ "	BUSHA	\$.45
525	$\frac{1}{4}$ "	BUSHB	.45
526	19/64"	BUSHC	.45
526	19/64"	BUSHC	.45

Bits

No.	Size	Shank	Code	Price
514	$\frac{1}{4}$ "	$\frac{1}{8}$ "	BITOA	\$1.45
515	$\frac{1}{8}$ "	$\frac{1}{4}$ "	BITOB	1.45
516	$\frac{3}{8}$ "	19/64"	BITOC	1.45
518	$\frac{1}{2}$ "	19/64"	BITOE	1.45

ATTACHMENT CONVERTS DRILL PRESS INTO MORTISER

Using our simple, easily installed attachments, our 11" and 14" drill presses can be used by anyone, even without previous experience, to make straight, true square-end mortises in all woods, and of practically any width, in a fraction of the time necessary by hand methods.

No. 976 Mortising Attachment for the 11" and 14" drill press enables mortising to be done from $\frac{1}{4}$ " to $\frac{1}{2}$ ", in any wood. Chisel holder clamps to quill in place of stop-rod casting. Fence carries hold-down casting and bracket for hooked rods. Capacity under hold-down up to $\frac{3}{4}$ " thick. Capacity from ends of hooked rods to fence $2\frac{3}{4}$ ". This attachment must be used with No. 974 spindle, which takes the regular bushings supplied for mortising chisels.

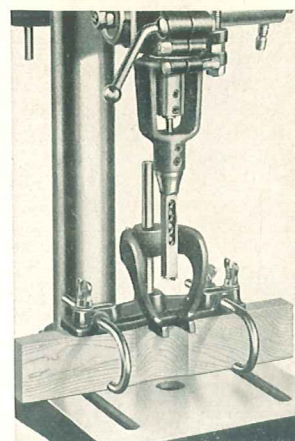

No. 976 Mortising Attachment for 11" and 14" drill presses, complete with fence, hold-down bracket, hold-down and rod, chisel holder, curved arms and bolts. Without No. 974 spindle **\$3.95**
Shipping Weight 8 lbs.
Code Word NEMOR.

Note: This mortising attachment can not be used on Drill Presses with Morse taper spindle.

MACHINE SPUR BITS



Made of selected steel, properly hardened and tempered for keen cutting qualities and long life, these machine bits are of exceptionally high quality. They have a diamond point and two cutting lips which sever the fibers of the wood and produce clean holes without any chipping of edges. All are approximately $6\frac{1}{2}$ " long overall, and have $\frac{1}{2}$ " shanks to fit standard $\frac{1}{2}$ " hole machine chucks, also mortiser spindle and No. 974 drill-press spindle.

No. 804	$\frac{1}{4}$ "	Machine Spur Bit.	Code SPURA	... \$1.10
No. 805	$\frac{3}{8}$ "	Machine Spur Bit.	Code SPURB	... 1.15
No. 806	$\frac{3}{8}$ "	Machine Spur Bit.	Code SPURC	... 1.20
No. 807	$\frac{1}{2}$ "	Machine Spur Bit.	Code SPURD	... 1.40
No. 808	$\frac{1}{2}$ "	Machine Spur Bit.	Code SPURE	... 1.55
No. 809	$\frac{1}{2}$ "	Machine Spur Bit.	Code SPURF	... 1.75
No. 810	$\frac{3}{4}$ "	Machine Spur Bit.	Code SPURG	... 1.95
No. 812	$\frac{3}{4}$ "	Machine Spur Bit.	Code SPURK	... 2.45

No. 818 Complete Set of 8 Machine Spur Bits, from $\frac{1}{4}$ " to $\frac{3}{4}$ " **\$12.30**
Shipping Weight 3 lbs. Code Word SPURL.

FOOT FEED FOR 14-INCH DRILL PRESS

Here—for the first time—is a foot feed for your 14" drill press which is thoroughly engineered for long life and maximum efficiency. There are only two links, which eliminates a number of sources of wear. The operating bracket is guided in a straight line by a heavy shaft carried in two substantial bearings. Pressure is applied to the quill on a line parallel to the spindle axis, which eliminates side thrusts on the quill, and consequently cuts down wear.

Adjustment of spring pressure over a wide range is simply a matter of moving a collar on the shaft—and the range is double by providing two springs, to suit tapping and mortising equipment of various weights.

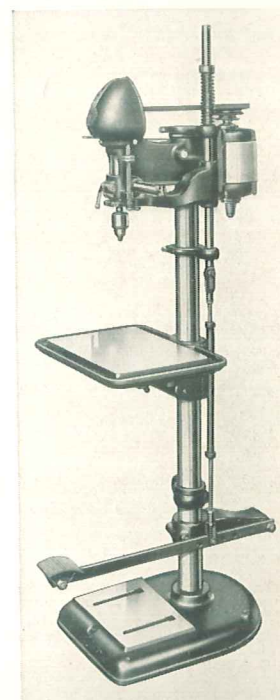

No. 1007 Foot feed for 14" drill press only, consisting of foot lever and bracket, connecting rods and tube, two column brackets, shifter bracket, shifter shaft, two springs and adjusting collar **\$15.00**
Ship. Wt. 30 lbs. Code Word NEWFF.

SPECIAL HOLLOW CHISELS ONLY



Made for the man who only occasionally has use for a mortising chisel these Hollow Chisels will be found an excellent value. They are the same sizes as the standard hollow chisels, and take the same bits and bushings. Not recommended for production work. Approximate Shipping Weight 10 oz. each. Have the cutting portion made of high carbon tool steel, carefully hardened and tempered. Shank of low carbon steel.

Cat. No.	Size	Depth of Mortise	Code	Price Each
634	$\frac{1}{4}$ " x $\frac{1}{4}$ "	$1\frac{1}{8}$ "	HOLOA	\$1.50
636	$\frac{3}{8}$ " x $\frac{3}{8}$ "	$2\frac{3}{4}$ "	HOLOC	1.50
638	$\frac{1}{2}$ " x $\frac{1}{2}$ "	$3\frac{1}{4}$ "	HOLOD	1.50

HIGH GRADE ROUTER BITS

Invaluable for routing, carving, round-end mortises and grooving work of all kinds. Shank diameter is $\frac{1}{2}$ ", to fit mortiser spindle, and No. 974 drill-press spindle. These router bits are of high-grade steel, tempered for real service.

Cat. No.	Size	Shank Dia.	Lg. of Flute	Code	Price Each
474	$\frac{1}{4}$ "	$\frac{1}{2}$ " x $1\frac{1}{2}$ "	$1\frac{1}{4}$ "	ROUTA	\$1.10
475	$\frac{1}{8}$ "	$\frac{1}{2}$ " x $1\frac{1}{2}$ "	$1\frac{1}{4}$ "	ROUTB	1.10
476	$\frac{3}{8}$ "	$\frac{1}{2}$ " x $1\frac{1}{2}$ "	$1\frac{1}{4}$ "	ROUTC	1.10
477	$\frac{1}{2}$ "	$\frac{1}{2}$ " x $1\frac{1}{2}$ "	$1\frac{1}{4}$ "	ROUTD	1.10
478	$\frac{1}{2}$ "	$\frac{1}{2}$ " x $1\frac{1}{2}$ "	$1\frac{1}{2}$ "	ROUTE	1.10

Shipping Weight 4 oz. each.

No. 480 Set of five Router Bits, sizes as above... **\$4.95**
Ship. Wt. 2 lbs. Code Word ROUTO.

PLUG AND DOWEL CUTTERS

There are countless jobs where the need of a tool to make short dowels or plugs, for screw holes is keenly felt. With these plug cutters, dowels up to 2" long and plugs up to 1" thick are cut as fast as the tool can be fed into the wood. All have $\frac{1}{2}$ " shanks to fit the No. 974 spindle. The $\frac{3}{8}$ " size is particularly adaptable to boat building, for cutting deck plugs.

Cat. No.	Size	Shank Dia.	Lg. of Cut	Code	Price Ea.
814	$\frac{3}{8}$ "	$\frac{1}{2}$ " x 2"	2"	PLUGA	\$3.10
815	$\frac{1}{2}$ "	$\frac{1}{2}$ " x 2"	2"	PLUGB	3.40
816	$\frac{5}{8}$ "	$\frac{1}{2}$ " x 2"	2"	PLUGC	3.95
817	$\frac{3}{4}$ "	$\frac{1}{2}$ " x 2"	2"	PLUGD	4.35
819	1"	$\frac{1}{2}$ " x 2"	2"	PLUGE	5.40

Shipping Weight Approximately 6 oz. each.

No. 822 Complete set of 5 Plug Cutters, sizes as above
Shipping Weight $2\frac{1}{2}$ lbs. Code Word PLUGS. **\$19.95**



DELTA INDUSTRIAL TOOLS

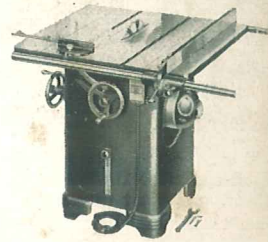

No. 1450 10" Tilting Arbor Circular Saw.



No. 1340 Floor Type Industrial Shaper



No. 666 6" Jointer on Cast Iron Production Base

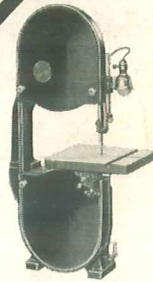

No. 880 14" Metal Cutting Band Saw



No. 1268 Pedestal Type Grinder



No. 1370 17" Floor Type Drill Press



No. 1545 Two Spindle 17" Drill Press and Standard Production Table

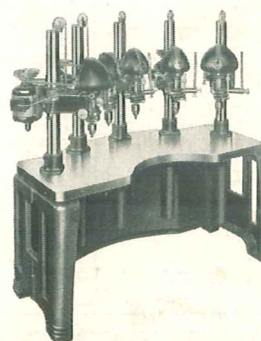

Special Production Set-up made of standard 14" heads and accessories.

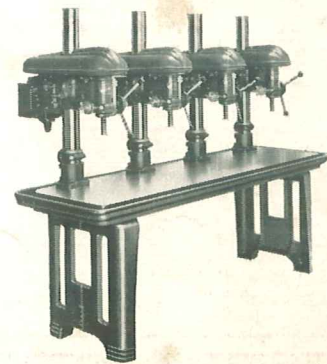

No. 1555 Four Spindle 17" Drill Press and Standard Production Table.

THESE INDUSTRIAL TOOLS ARE USED IN THOUSANDS OF FACTORIES WHERE THEIR ACCURACY, RUGGED CONSTRUCTION AND LOW COST PROVIDE RELIABLE, ECONOMICAL OPERATION

In addition to the quality tools shown in this catalog, Delta makes a complete line of Industrial Tools, a few of which are shown here. These Industrial Tools have found their way into thousands of factories and production shops all over the country because alert production men and operators found in them a way to increase production and cut costs.

Their ability to "take it" in these shops is due to their inherent correct mechanical design—their careful precision manufacture and their advanced engineering, which have made them the leaders in their field. Further information will be sent upon request.

THE DELTA MANUFACTURING COMPANY
MILWAUKEE WISCONSIN